

CHADSWORTH'S 1.800.COLUMN[®]

AUTHENTIC REPLICATION

General Information



- Storage of columns must be in a dry and well ventilated area.
- Before installation, on columns primed at the factory, paint all wooden parts with 2 coats of oil-based exterior paint. We do not recommend storing wood columns. If they must be stored, however, they must be painted first and stored in a dry, well-ventilated area to protect against moisture.
- If a furniture finish is desired, additional sanding and priming will be required.

Columns not primed should be primed with an oil-based exterior primer and painted with 2 coats of an oil-based exterior paint.

DO NOT USE LATEX PAINT!

Columns must be completely protected from moisture before and after installation. Priming of the column does not protect the column from moisture.

A

Ventilation For Exterior Columns

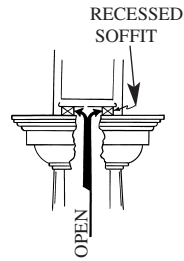

Ventilation must be provided at the top of the columns by a recessed soffit and at the bottom of the column by the plinth or plates. This ventilation must be maintained at all times.

Plates For Greek Doric Columns

Columns without ventilation plinths have 1/4" thick plates which are positioned beneath the column shaft to provide ventilation. Dowels are placed in deck/floor so they will go through the plates.

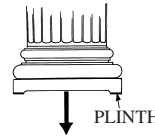

Ventilation is imperative for the longevity of your column. If column is not properly vented, the paint may peel and the column may crack. Your warranty would be voided if not properly vented.

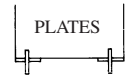
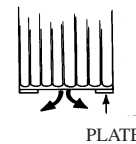

B

Fiberglass Plinth Assembly



- Determine position of plinth by dropping a plumb line from center of beam to deck. This point on the deck will be the center of the plinth so that the top of the shaft will align with the soffit.
- Install corrosion resistant dowels into the floor. These dowels should fit in opposite corners of the plinth and will prevent the plinth from moving laterally.
- Level the plinth to the floor, if necessary, by scribing the plinth to the floor. Make sure that the original ventilation area is maintained which may necessitate enlarging the opening. The plinth **must** be level before proceeding to the next step.

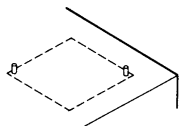

1/4" + 1/8"

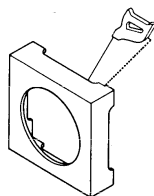
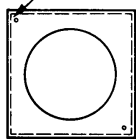

C

Fiberglass Base Assembly

- Position wood plug within plinth and check that plug is level. If the plug is not level, remove the plastic attached to the bottom of the leg(s), as needed to level the top of the plug. The plastic parts should be reattached at the bottom of the legs.
- Do a trial fit with the base over the plinth and plug. Be certain that the fiberglass will be under no pressure when the weight of the shaft is on the base. The plug must carry the shaft load.
- Run a bead of construction adhesive around top of plinth. Place fiberglass base molding over the wood plug and press onto the plinth.

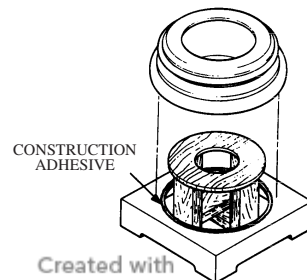
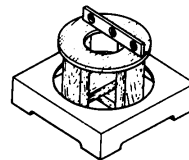

Created with

AUTHENTIC REPLICATION

Cast Aluminum Plinth Assembly

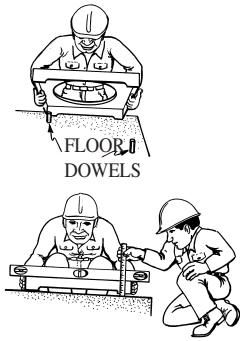

- Install corrosion resistant dowels into the floor. These dowels should fit in opposite corners of the plinth and will prevent the plinth from moving laterally.
- Level the plinth to the floor, if necessary, by scribing the plinth to the floor. Make sure that the original ventilation area is maintained...this may necessitate enlarging the opening. It is very important that the plinth is level before proceeding to the next step.
- The base molding should be attached to the plinth by:

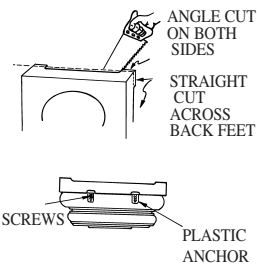

- Turning the plinth and base molding upside down.
- Centering the plinth over the base molding.
- Locating the pre-drilled holes in the plinth. Using these holes as a guide, drill 3/16" holes into the base molding.
- Insert the anchor flush with the bottom of the base molding.
- Using the 1 1/4" screws and washers, screw through the plinth into the anchor.

- Place the base assembly over the corrosion resistant dowels. Proceed to shaft assembly.

A

Wooden Plinth Assembly

- Place headless nails (blunt side to the base) into the bottom of the pre-drilled holes located in the bottom side of the base molding.
- Center the base molding over the plinth.
- Press them together (nails will set into the plinth.)
- Screw or nail the base assembly to the floor.
- Proceed to shaft assembly.

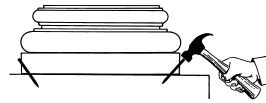
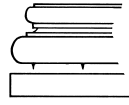

B

Shaft Assembly



If the column shafts are trimmed to different lengths, the bottom end grain must be sealed and painted with a waterproofer or wood preservative and painted with an exterior oil-based paint to help prevent moisture related cracks and premature decay or rot.

Fiberglass Base Molding

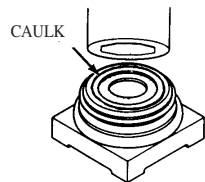

After caulking top of base, lift shaft with capital in place onto the base and tilt into position under recessed soffit. Shaft should be centered on base.

- Pre-drill holes through soffit into wood cap plug. Fasten soffit to capital with 2 1/2" long brass screws.
- Pre-drill holes through shaft into base plug. Fasten shaft to base by driving 2 1/2" long brass screws through shaft.
- All joints should be sealed with a paintable silicone caulk.

C

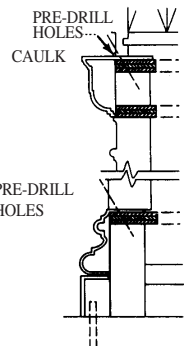

Cast Marble Base Molding

Pre-drill holes at top of base molding. Place headless nails (blunt side down) into holes. If additional holes are desired, use a steel cutting drill bit. Headless nails can be made by cutting off galvanized nails.

Place shaft onto base. The weight of the shaft should set nails into the shaft.

Wooden Base Molding

Place shaft onto base. Nail or screw shaft to base.

Use a paintable silicone sealant to seal the joint between the shaft and the base molding.

For split columns see Special Instructions on page 6.

Proceed to Capital Installation.

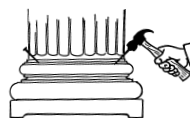
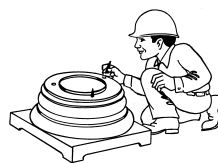

Created with

nitro PDF professional

AUTHENTIC REPLICATION

Fiberglass Capital Assembly

- Center wood plug on top of shaft and secure in place with wood screws.
- Caulk area where capital will meet shaft. Place capital over plug.

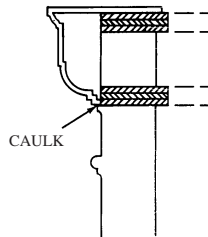
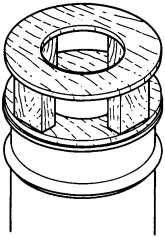

A

Plain Wood Capital Assembly

- Install flashing over capital by bending the metal over the edge of the capital.
- Nail or screw capital to column shaft.
- Nail or screw capital to soffit.
- Use paintable silicone sealant to seal the joint between soffit and flashing, between shaft and capital, and between shaft and base.

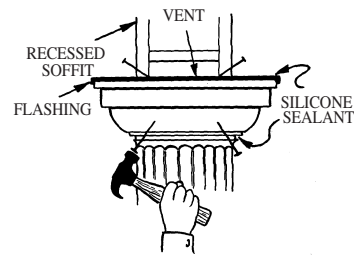

B

Decorative Composition Capital

- Do not store decorative capitals in their original crates—they must be painted first.
- Before installing a composition capital, it must be painted with two coats of oil-based exterior paint. **If moisture gets into the capital, it may disintegrate.**



- Composition capitals are **not load bearing unless ordered that way**. Please see instructions for making the wooden plug.
- Install wooden plug onto the shaft with wood screws or nailing plug to shaft.
- For exterior installation, install flashing over top of capital by bending the metal over the edge of the capital.

- Center capital over plug. Pre-drill through capital into plug. Attach with brass screws long enough to bite into the plug. Set screw heads below surface of capital and fill with patching plaster.

- Lower soffit onto wooden plug. Make sure no weight is on the capital. Nail or screw plug to soffit.

- Use shims to lock plug into place on interior columns where the soffit cannot be lowered.

- Caulk area where capital will meet shaft. Seal all joints with a paintable silicone sealant.

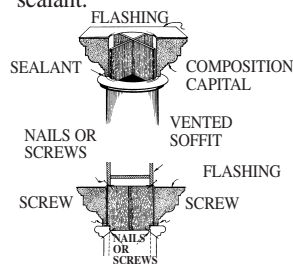

C

Load-bearing Plug—Not Necessary If You Purchased Load-Bearing Capitals

Recommended 3/4" plywood.

a = width of opening at top of capital

b = height of capital - measured on inside + 1/4"

c = a - e + 2

d = 2" to 4"

e = width of opening at top of shaft

f = 1/2 of a

g = 1/2 of b + d

h = 3/4"

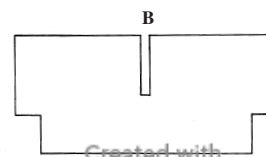
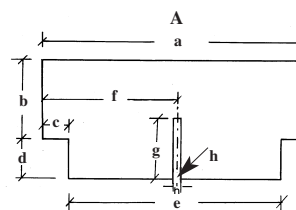
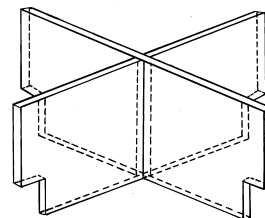

Created with

SPECIAL INSTALLATIONS

Split Columns

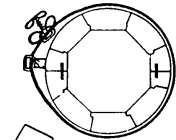

Columns that are split to surround a structural steel beam should be installed similarly to unsplit columns. However, the following procedures should be followed in putting the split parts back together.

Keep all seams at 90 degree to front view. Halves will arrive marked. Be careful to keep proper halves together.

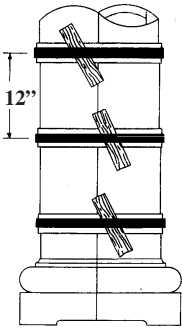

2. The shaft should be glued using exterior waterproof glue. Follow glue manufacturer's instructions for applying glue. Do a trial fit before applying glue to the wood.

3. Place nylon clamps or steel strapping not less than one foot apart along the length of the shaft. To prevent damage to the shaft, use protective material beneath the clamps before tightening.

4. Adjust clamps and use blocking where necessary to pull column into round. It may also be necessary to tap along seam with a rubber mallet. Check and be certain there is complete contact all along the joint, then remove excess glue.

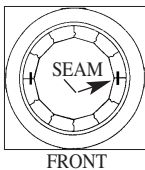

5. Fill any gaps and all seams with wood filler and sand smooth with 100 grit sandpaper. Immediately reprime and paint with an exterior oil-based primer and paint.

A

Using as Pilasters

Columns which are split for pilasters must be caulked around all edges to prevent moisture from entering the shaft.

1. Apply a furring strip as a nailer the entire length of the pilaster and capital from floor to ceiling.
2. Drill pilot holes for screws on each side of the seam and angle to attach to the shaft.
3. Counter sink screws into the strips of wood.
4. Fill all seams and caulk the areas of the capital that attach to shaft.

B

Fiberglass Base/Plinth

The two-piece wood plug should be joined with wood screws. The fiberglass base halves should be joined with epoxy cement.

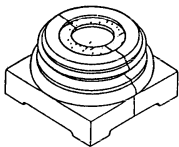

Cast Marble Base/Aluminum Plinth

1. Fill aluminum plinth joints with liquid aluminum.
2. Fill joints in marble parts with an automobile body filler.
3. Glue wood caps and bases using exterior waterproof glue.

Joining Fiberglass Capitals

Refer to capital installation. The two-piece wood plug should be joined with wood screws. The fiberglass halves should be joined with epoxy cement.



Joining Wood Capitals & Bases

Refer to capital installation. The wood halves should be joined using exterior waterproof glue.

C

Joining Split Decorative Composition Capitals

1. Follow general instructions for capital installation.
3. Drill pilot holes for screws on each side of the seam and angle to attach to the shaft.
3. Caulk the areas of the capital that attach to shaft.
4. Clean cut surfaces of capital with shellac. Use a bead of construction adhesive along the seams.
5. Press the two halves together and allow to dry completely.
6. Using galvanized or stainless steel screws, attach the capital to the shaft or plug.
7. Caulk around all edges making certain that no parts are exposed.
8. Put patching plaster along the seam and sand to make it smooth.

Decorative Capital Repairs

Cracks - If a capital should get a very small crack, then make the crack slightly larger and apply a coat of shellac and let dry. The thin edge of a small putty knife or any similar object inserted into the crack will enlarge it slightly. Then put a plaster or molding compound over the crack and allow to dry.

Broken Pieces - Shellac both pieces and then glue them together with any high quality wood bonding agent.

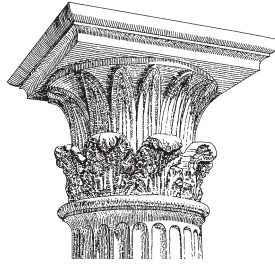

INHERENT CHARACTERISTICS OF WOOD

This advisory concerns prevention of dimensional problems in architectural woodwork products as the result of uncontrolled relative humidity. It is further intended as a reminder of the natural dimensional properties of wood and wood-based products and of the routine and necessary care and responsibilities which must be assumed by those involved.

For centuries, wood has served as a successful material for architectural woodwork, and as history has shown wood products perform with complete satisfaction when correctly designed and used. Problems directly or indirectly attributed to dimensional change of the wood are usually, in fact, the result of faulty design, or improper humidity conditions during site storage, installation, or use.

Wood is a hygroscopic material, and under normal use conditions all wood products contain some moisture. Wood readily exchanges this molecular moisture with the water vapor in the surrounding atmosphere according to the existing relative humidity. In high humidity, wood picks up moisture and swells; in low humidity wood releases moisture and shrinks. As normal minor fluctuations in humidity occur, the resulting dimensional response in properly designed construction will be insignificant. To avoid problems, it is recommended that relative humidity be maintained with the range of 25%-55%. Uncontrolled extremes (below 20% or above 80% relative humidity) can likely cause problems.

Together with proper design, fabrication, and installation, humidity control is obviously the important factor in preventing dimensional change problems.

Architectural woodwork products are manufactured as designed from wood that has been kiln dried to an appropriate average moisture content and maintained at this condition up to the time of delivery. Subsequent dimensional change in wood is and always has been an inherent natural property of wood. These changes cannot be the responsibility of the manufacturer or products made from it. Specifically:

- Responsibility for dimensional change problems in wood products resulting from improper design rests with the designer/architect/specifier.
- Responsibility for dimensional change problems in wood products resulting from improper relative humidity exposure during site storage and installation rests with the contractor.
- Responsibility for dimensional change problems in wood products resulting from humidity extremes after occupancy rests with engineering and maintenance.

It is normal for wood to expand or contract with changes in atmospheric conditions. Wood will adjust to climate. Checking may occur.

VARIATIONS IN NATURAL WOOD PRODUCTS

Wood is a natural material, with variations in color, texture and figure. These variations are influenced by the natural growing process and are uncontrollable by the woodworker. The color of wood within a tree varies between the “sapwood” (the outer layers of the tree which continue to transport sap), which is usually lighter in color than the “heartwood” (the inner layers in which the cells have become filled with natural deposits). Various species produce different grain patterns (figures), which will influence the selection process. There will be variations of grain patterns with any selected species. The architectural woodworker cannot select solid lumber cuttings within a species by grain and color in the same manner in which the veneers may be selected. Color, texture, and grain variations will occur in the finest architectural woodworking.

Reprinted with permission as published by the Architectural Woodwork Institute, Reston, VA

Created with



download the free trial online at nitropdf.com/professional

VENTILATION INSTRUCTIONS

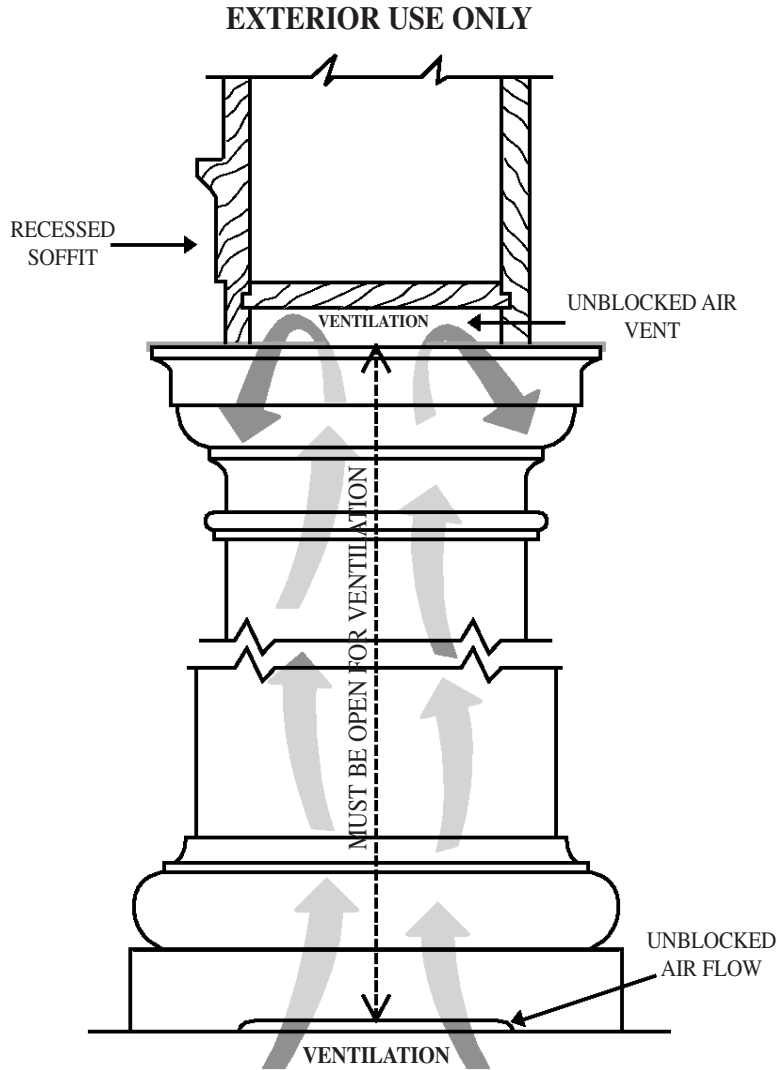

Ventilation must be provided at the top and bottom of the columns. Air flow must move through the center of the column, capital and flashing into a recessed soffit and through the base and plinth.

The installing contractor must provide this ventilation with a recessed soffit and open plinth for the warranty of the column.

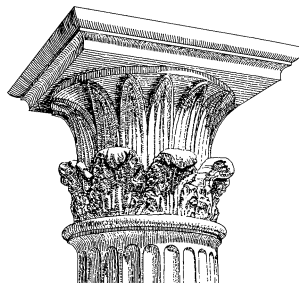

CHADSWORTH'S 1.800.COLUMNNS®
www.columns.com

1.800.486.2118

HISTORIC WILMINGTON, NORTH CAROLINA
910.763.7600 • FACSIMILE 910.763.319
ATLANTA • LONDON

Created with



nitroPDF® professional

download the free trial online at nitropdf.com/



CHADSWORTH'S 1.800.COLUMNS®

www.columns.com

Decorative Capitals / Installation Instructions

Marble Fiberglass Reinforced Polymer Composite Product

A. PARTS AND SUPPLIES NEEDED FOR INSTALLATION

Hardware not included:

The following will need to be purchased before beginning installation.

- Standard construction adhesive
- Mineral spirits - for cleaning
- High quality primer and topcoat paint

B. PREPARATION

1. General – Good industrial/construction safety practices demand that when grinding, cutting, or sanding our products, you must work in a well-ventilated area and wear protective safety equipment, such as safety gloves, safety glasses and a MSHA/NIOSH approved respirator.
2. Installation - It is recommended that safety gloves, hard hats and safety glasses, as well as other specified safety equipment be used during installation.

NOTE: Decorative Capitals are load bearing to meet the level of load bearing capacity of the column.

C. INSTALLATION OF DECORATIVE CAPITALS

1. Before installing the decorative capital, cut the column at the top of the shaft just above the neck ring within 1/8" from the neck ring and belt sand flush to finish (see Fig. A). This step does not apply for fiberwound columns that are without a neck ring or where the ring is at the top of the column shaft.
2. **Before cutting the bottom of the column shaft** – measure the opening where the column will be installed. When calculating the overall height required be sure to include the height of the capital. Trim the column shaft bottom to fit the height of the opening.

NOTE: Column may be trimmed using an abrasive saw blade or a fine-toothed hand saw. The capital may be trimmed using a Sawzall® with an 8" or 10" / 14 teeth per inch saw blade.

3. Apply a good grade of construction adhesive between the top of the column shaft and the bottom of the capital (see Fig. B).
4. Center the capital on the top of the column. Remove any excess adhesive.
5. Countersink three [3] screw holes below the neck ring up through the base of the capital. Screws should be long enough to penetrate the base of the capital (see Fig. B).
6. Secure the capital with three galvanized or stainless steel [rust-proof] screws. Do not over tighten.
7. Raise soffit and slide assembled column with attached capital into place. Follow the column manufacturer's installation instructions.

D. INSTALLATION OF SPLIT COLUMNS AND CAPITALS

NOTE: Split columns and split capitals are not load bearing.

Join the two capital halves using a good grade of construction adhesive. Caulk all seams and finish as described below.

E. INSTALLATION INSTRUCTIONS TO COVER THE CAVITY OF THE CAPITAL

1. Using 3/8" or 1/2" Marine grade plywood, place the plywood on the top of the capital and trace an outline of the capital.
2. Over cut the tracing by 1/4".
3. Apply a premium grade of silicone between the plywood and the capital top.
4. Screw the plywood to the capital using stainless steel screws.
5. Caulk the back edge of the plywood where it meets the soffit with silicone adhesive.
6. You may also use flashing, or a combination of both flashing and plywood. There is no need to bend the flashing over the edge of the capital. This product is rot proof and impervious to water.

Created with



277 NORTH FRONT STREET • HISTORIC WILMINGTON, NC 28401-3907 • TOLL FREE 1.800.486.2118 • TELEPHONE 1.910.763.7600 • TELEFAX 1.910.763.3191

download the free trial online at nitropdf.com/professional

ATLANTA • LONDON

CHADSWORTH'S 1.800.COLUMN[®]

www.columns.com

Decorative Capitals / Installation Instructions

Marble Fiberglass Reinforced Polymer Composite Product

F. FINISHING

1. Finish by caulking all seams and drill holes.
2. Repairs to the capital may be made using automotive adhesive such as Bondo®.
3. Apply a high quality primer to both the column and capital.
4. Finish with a premium grade of topcoat paint (see Fig. C).

OTHER INFORMATION

It is always advisable to check your local building codes before starting construction. If you have any questions regarding these installation instructions, please contact the manufacturer before starting installation.

Manufacturer shall not be responsible if any failure to comply with these instructions results in the product failing to perform the purpose intended. Failure to comply with the above instructions shall result in voiding the terms and conditions as stated in the warranty.

Fig. A – Cut Column at neck ring when installing decorative capitals.

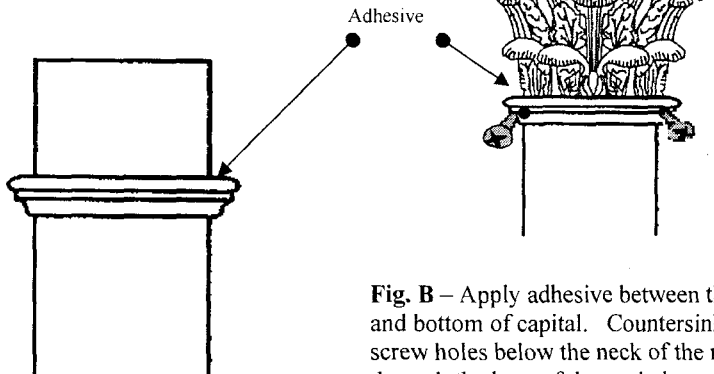
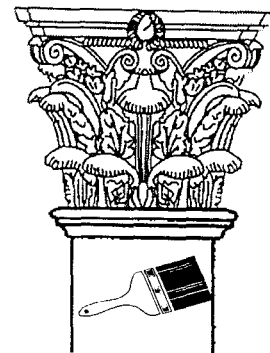

Fig. B – Apply adhesive between the top and bottom of capital. Countersink 3 screw holes below the neck of the ring through the base of the capital.

Fig. C – Apply a high quality primer before painting.



Created with

 **nitro**PDF[®] professional

277 NORTH FRONT STREET • HISTORIC WILMINGTON, NC 28401-3907 • TOLL FREE 1.800.486.2118 • TELEPHONE 1.910.763.7600 • TELEFAX 1.910.763.3191

download the free trial online at nitropdf.com/professional

ATLANTA • LONDON