

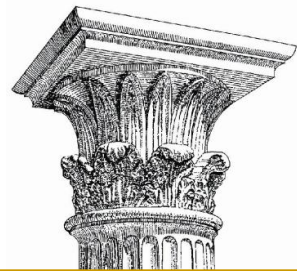

CHADSWORTH COLUMNS

www.columns.com



CLASSIC STONE BALUSTRADES – INSTALLATION

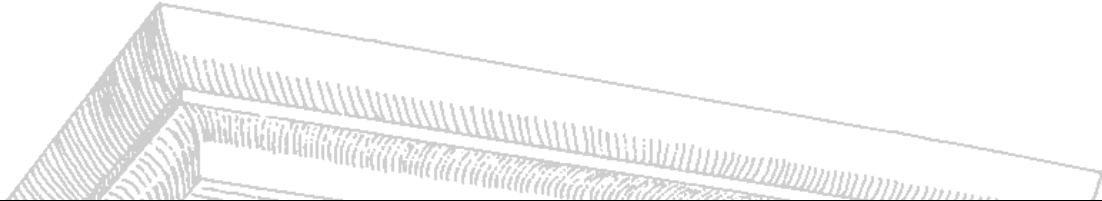

STEP 1: POST INSTALLATION – (Hardware not included in kit)

Required tools: screw driver, pencil, 3/4 dia. concrete drill bit for installation over concrete
Place newel post in position on flooring as specified on architectural plans and as adjusted by field measurements. Center newel post accordingly. Mark flooring around edges of newel post.
Put newel post aside until later.

1. Installation over wood flooring: (see figure 1A)

Fasten iron flange for 1" pipe, with appropriate wood, in the center of the area marked for newel post. Thread 1" steel pipe into the iron flange. Note: pipe length should be approximately 1/2 height of the newel post.

2. Installation over concrete flooring: (see figure 1B)

Drill (2) 3/4 dia holes x 3" deep in concrete, centered 4" apart, in the area marked for the newel post. Insert reinforcement rod. Note: rod length is approximately 1/2 height of the newel post. Align newel post as marked on deck. Pour light weight concrete to a level approximately 1/3 the height of the newel post. Do not place newel caps on posts until hand rails are installed.

Tip: If there is a concern of the alignment or accuracy of the entire assembly, pour light weight concrete between steps 8 and 9.

This will enable a final adjustment and alignment.

www.COLUMNS.com

CHADSWORTH INCORPORATED

277 NORTH FRONT STREET ▪ HISTORIC WILMINGTON, NC 28401 ▪ PHONE: 1.800.486.2118 ▪ FACSIMILE: 1.910.763.3191 ▪ E-MAIL: sales@columns.com

FIGURE 1A

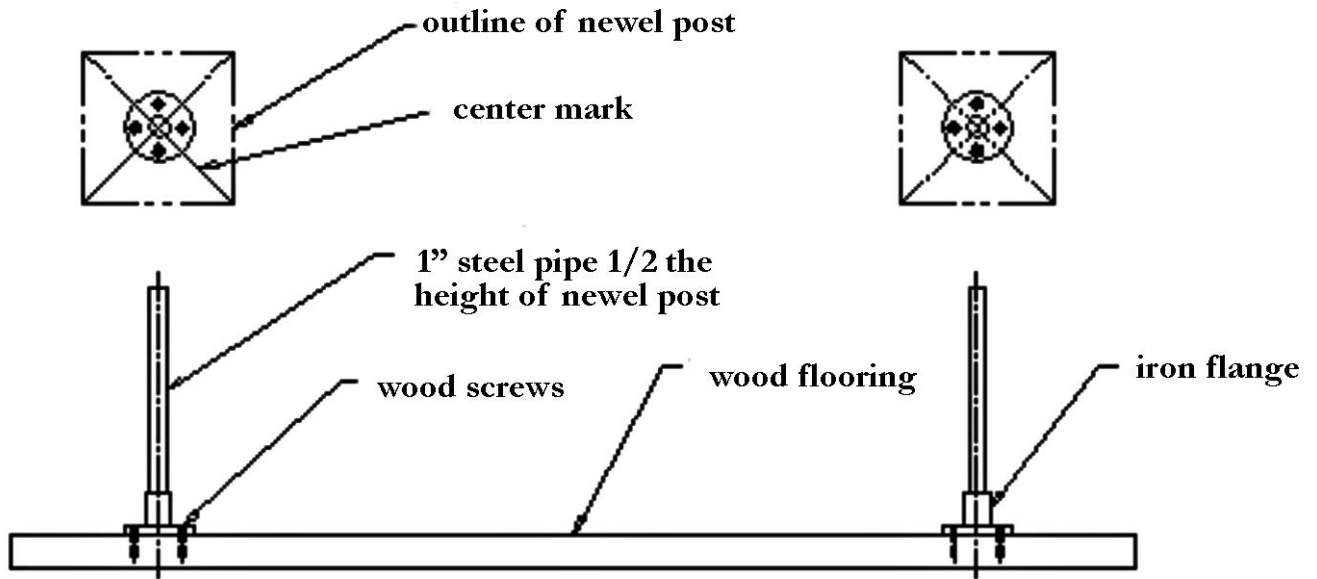
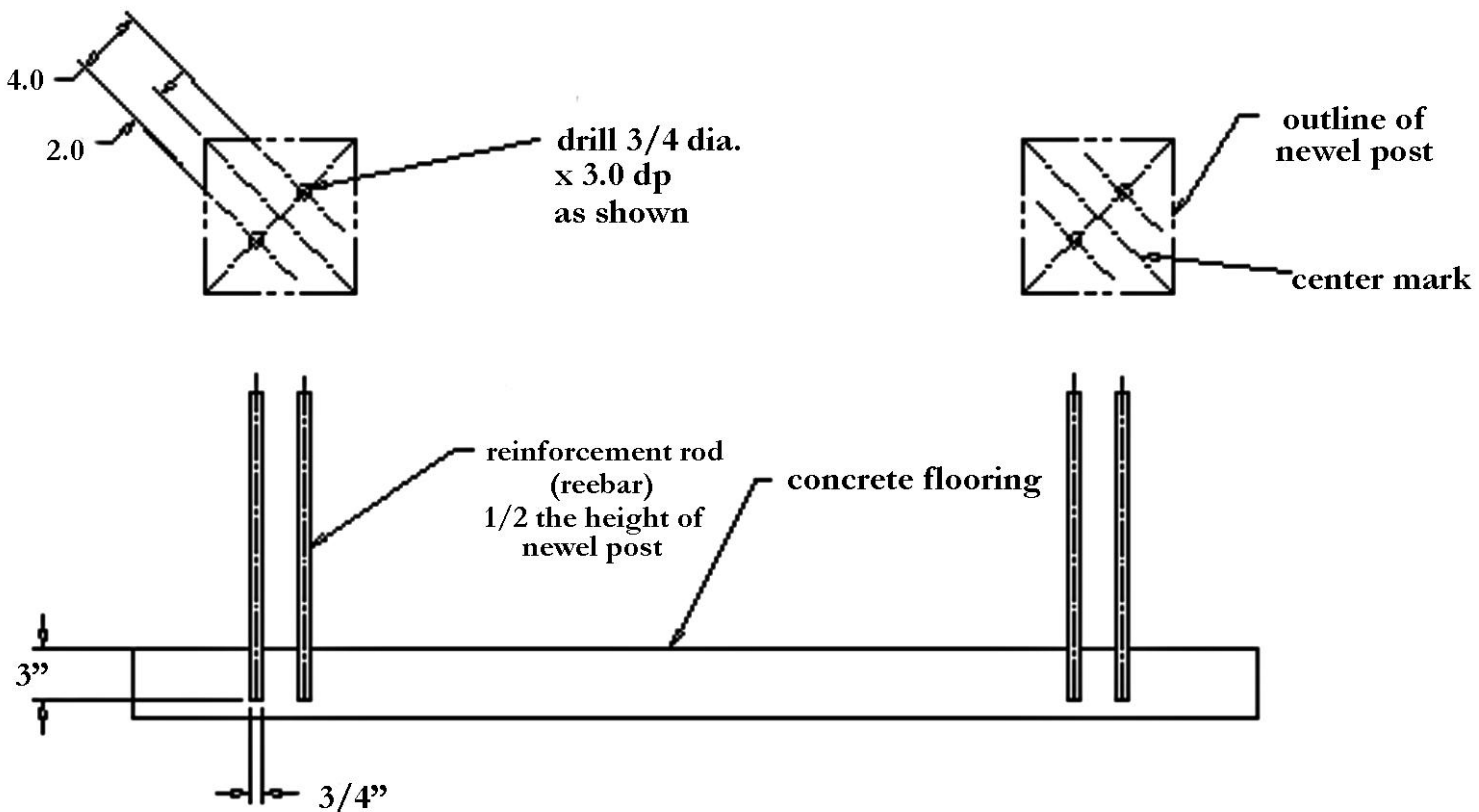

FIGURE 1B



STEP 2: BOTTOM & TOP RAIL PREPARATION

Required tools: circular saw, and carbide or diamond saw blade.

Use carbide saw blade or diamond disc. Cut rails $\frac{3}{8}$ " shorter than measured distance between newel posts.

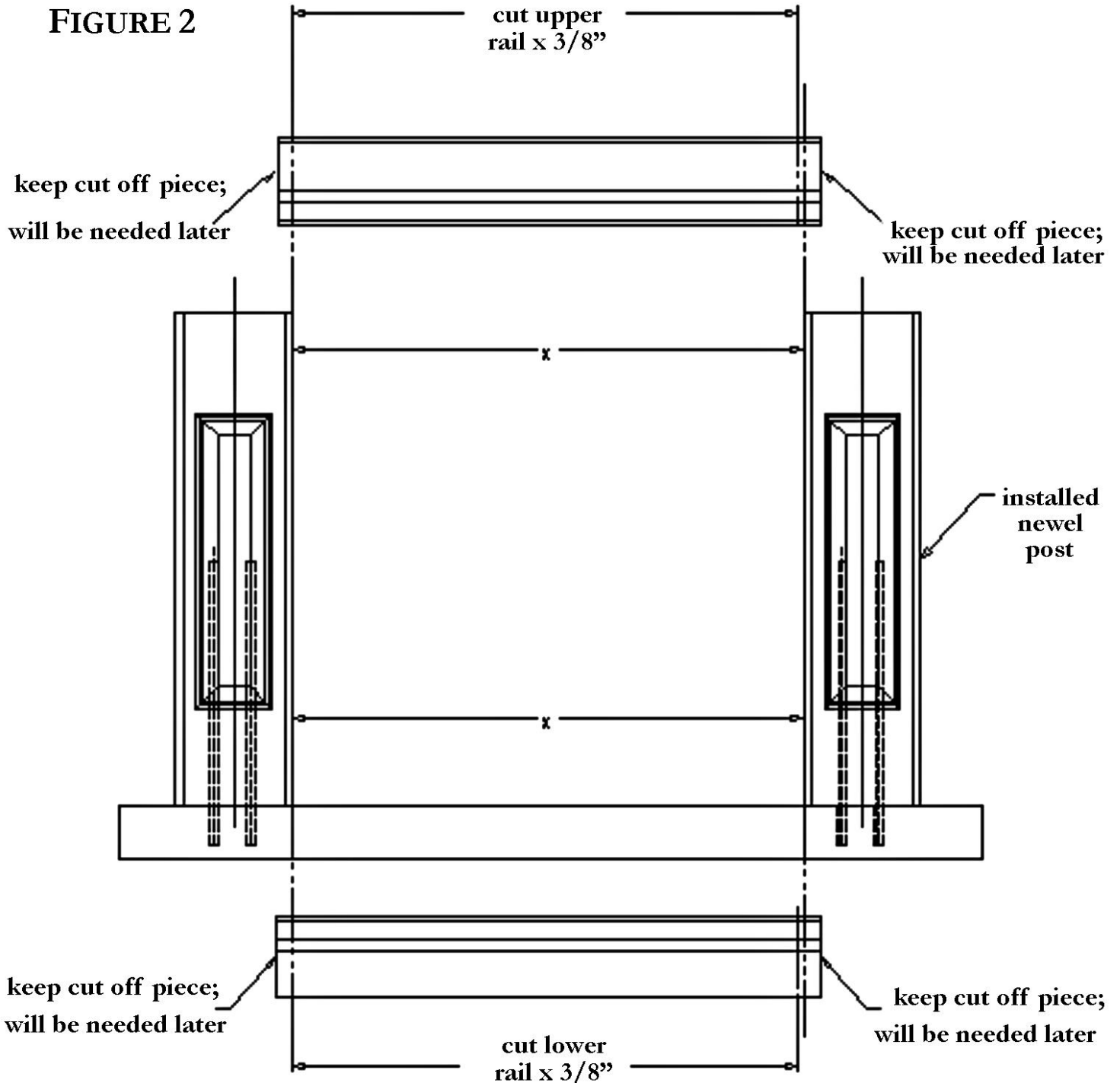

www.COLUMNS.com

CHADSWORTH INCORPORATED

277 NORTH FRONT STREET ▪ HISTORIC WILMINGTON, NC 28401 ▪ PHONE: 1.800.486.2118 ▪ FACSIMILE: 1.910.763.3191 ▪ E-MAIL: sales@columns.com

STEP 3: DRILLING OF HOLES IN RAILS

Required tools: drill, 1 1/8" dia with 1/4 dia pilot hole saw, pencil.

-6" (sphere) spacing: (see figure 3)

Mark the first hole on each side, 4" to 6" from each end, divide the remaining space between the 2 end holes equally.

The center distances must be between 6.5" and 8.5" for each baluster.

Space between baluster centers may not exceed 7.5".

-4" (sphere) spacing:

Mark the first hole on each side, 4" to 6" from each end, divide the remaining space between the 2 end holes equally.

The center distances may not exceed 6.5".

Tip: During hole drilling rotate drill few degrees to ease cut out removal from tool.



FIGURE 3

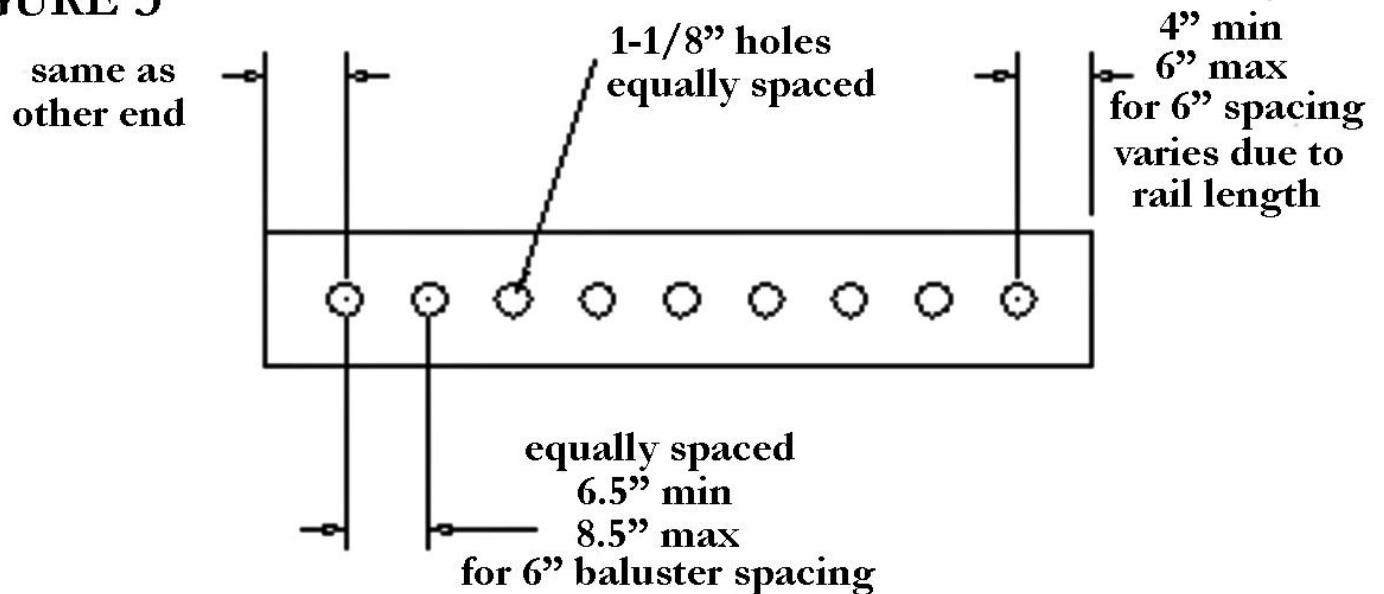

STEP 4: NEWEL POST HOLES FOR RAIL CONNECTION

Required tools: drill, 5/8" diameter carbide drill bit, level and pencil.

Install rail spacers at 2 ft. spacing if necessary. Position lower rail between newel posts. Install 2 balusters into pre-drilled side holes. Level bottom rail, install, position and level upper rail.

Scribe rail outlines on newel posts. (at all 4 rail ends) Remove rails and balusters (see figure 4A).

Using rail end cut off pieces, match scribed outlines and transfer holes into newel posts, using 5/8" diameter carbide drill bit.

Note: It is always the best practice drill 2 holes diagonal to each other (see figure 4B).

FIGURE 4A

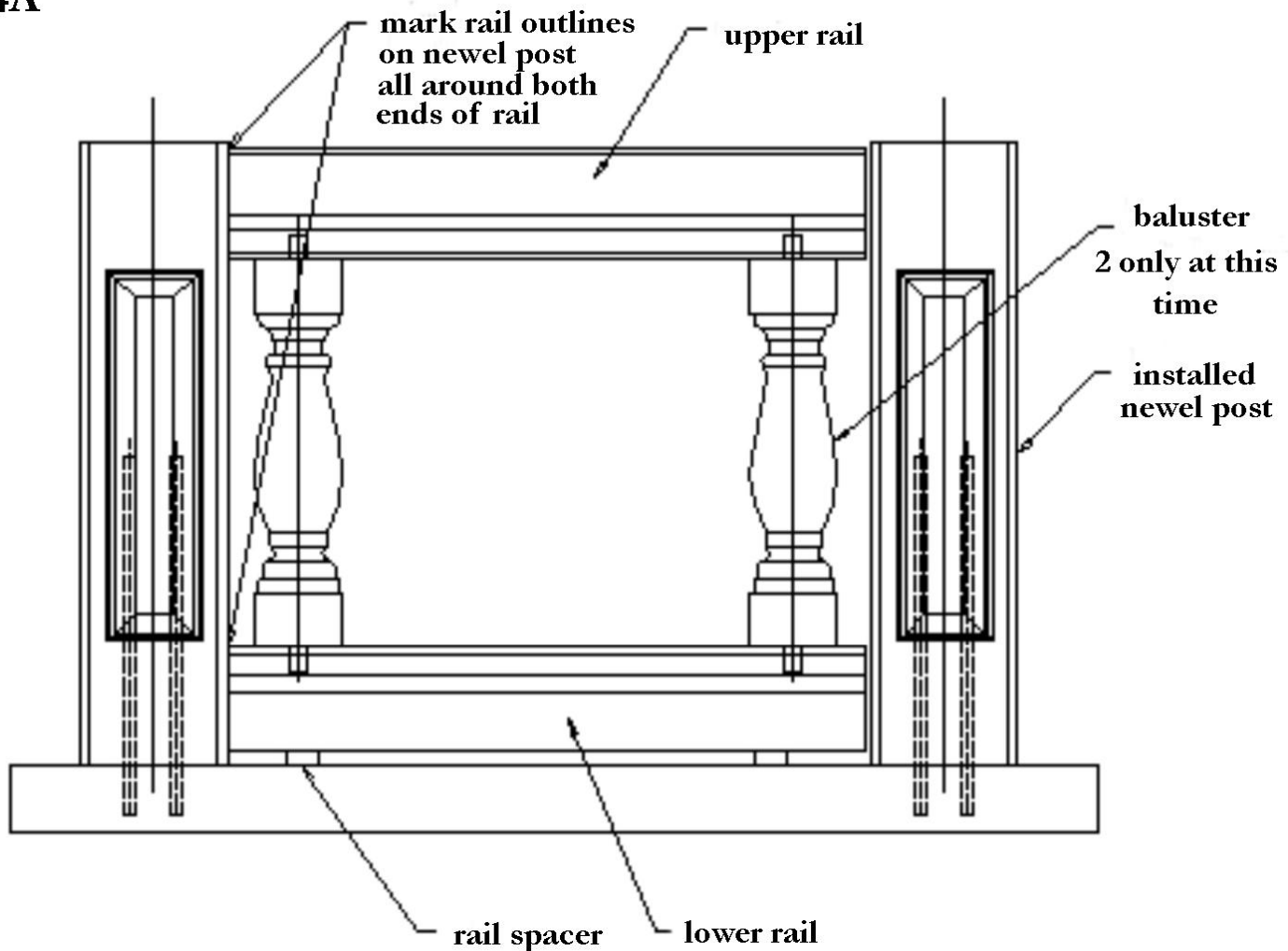

www.COLUMNS.com

FIGURE 4B

lower rail



best practice is to transfer diagonal holes using 5/8" diameter carbide drill bit

upper rail

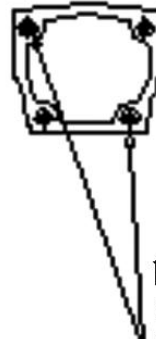

best practice is to transfer diagonal holes using 5/8" diameter carbide drill bit

STEP 5: SPRING LOADED PIN INSTALLATION

Inspect pvc pipe ends. Clear ends, if necessary, using a round file. Do not force pin into pipe!

Insert steel pin into open end of spring. Insert this spring loaded pin assembly into 2 of the small holes matching the holes drilled into the newel posts. If bracket becomes jammed, slowly turn pin clockwise and gently push (see figure 5).

FIGURE 5

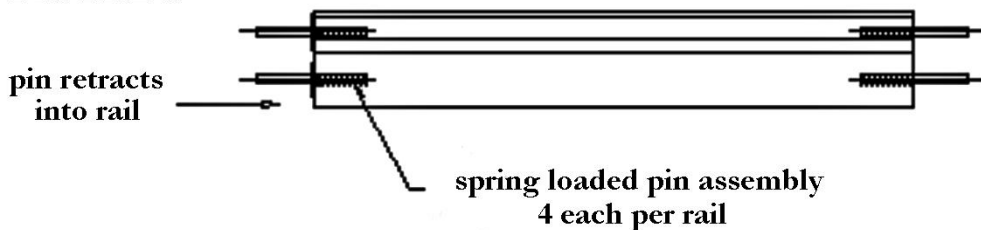

when inserting pin assembly, match drilled hole pattern in newel post

STEP 6: INSTALLATION OF BOTTOM RAIL

Accessories required: general construction adhesive, wood shims.

Place rail spacers, if used, at approximately 2 ft spacing for each other. Apply glue. Under 4 ft post distance, use at least 2 spacers.

Place general construction adhesive inside holes at bottom of newel post prior to placement and installation of bottom rail.

Place rail to have 3/16 gap at each end. Use wooden shims to lock rail into position until glue hardens. (see figure 6).

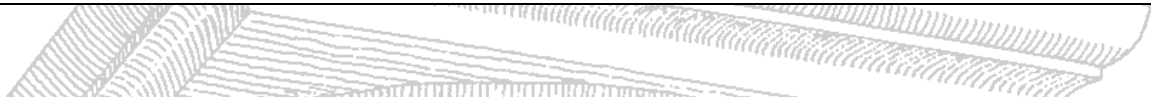
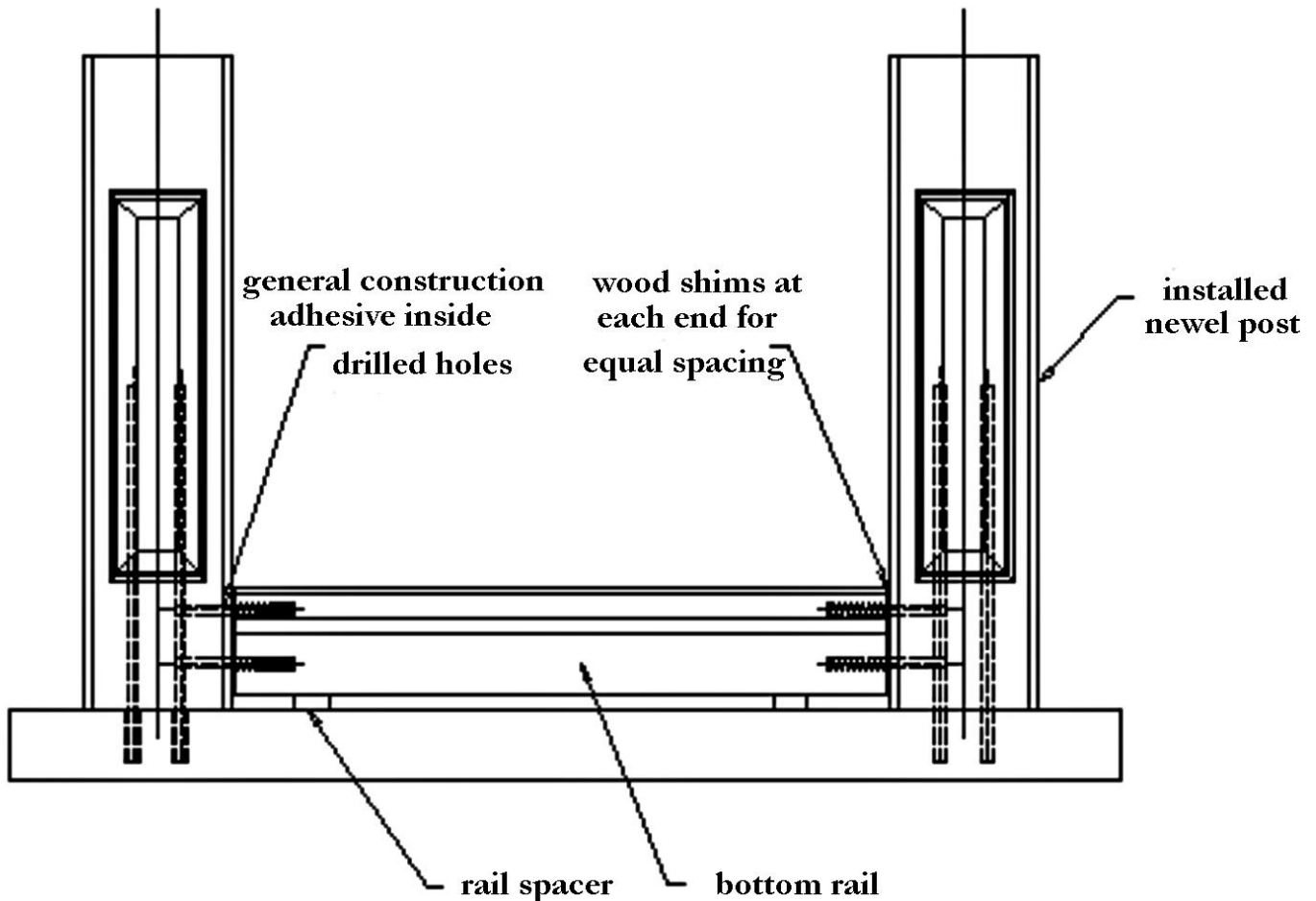

FIGURE 6



STEP 7: POSITION THE BALUSTERS ON THE BOTTOM RAIL

Accessories required: general construction adhesive. Place general construction adhesive 1/2" around pre-drilled holes of bottom rail. Insert and carefully position balusters into holes.

Note: Be sure glue does not squeeze out when positioning the balusters (see figure 7).

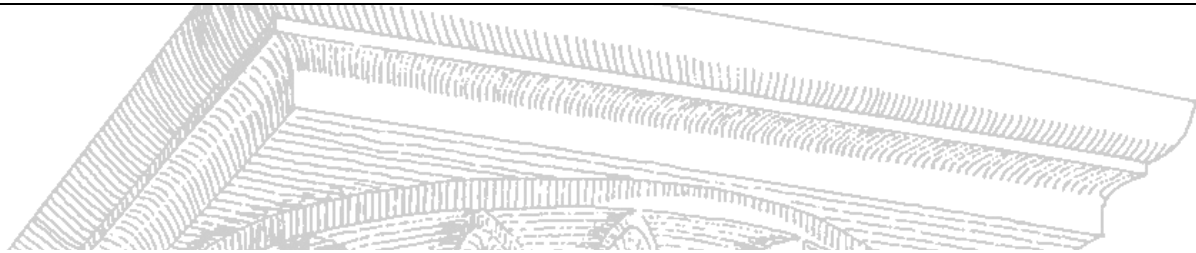
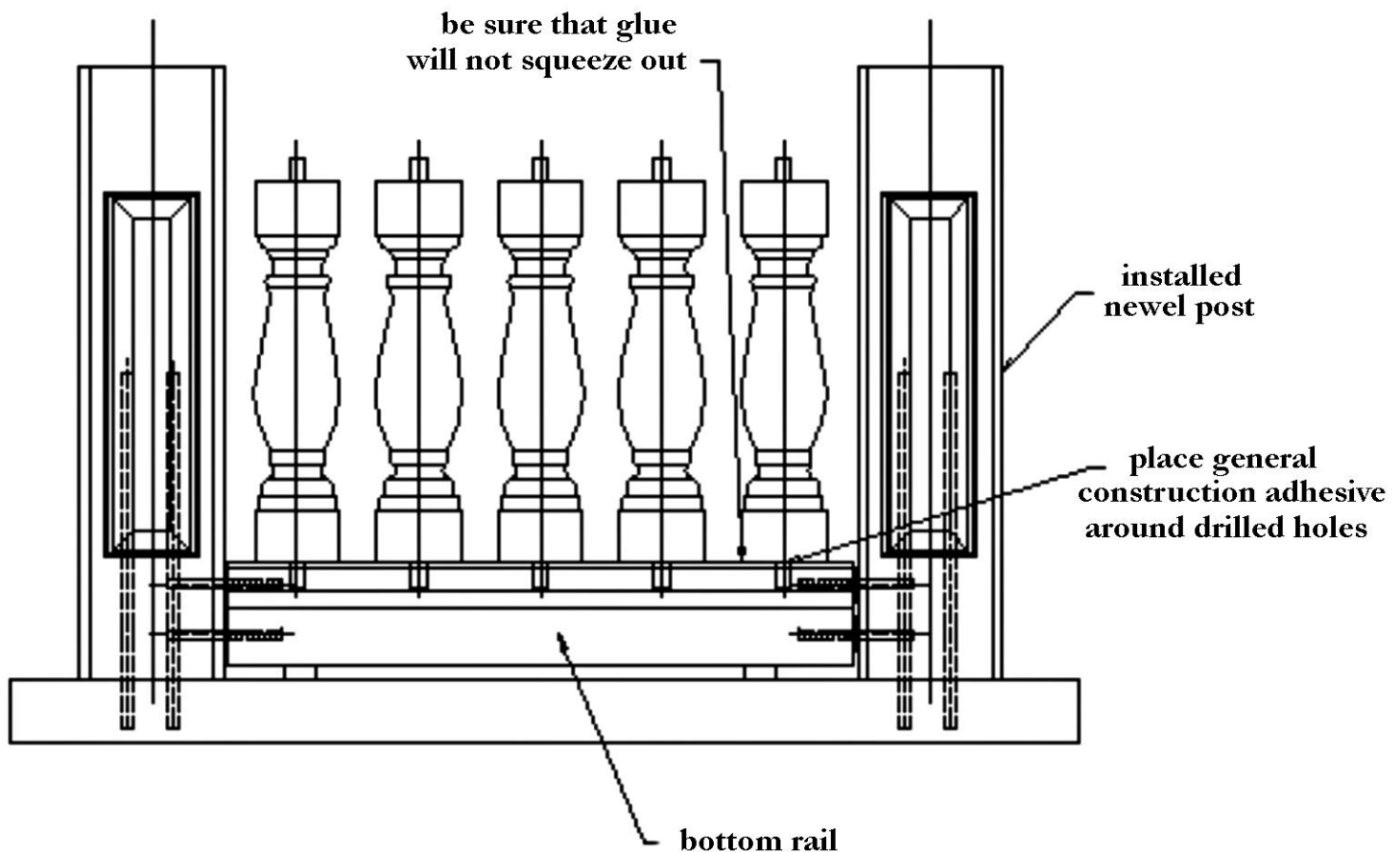

FIGURE 7



www.COLUMNS.com

STEP 8: INSTALLATION OF TOP RAIL

Accessories required: general construction adhesive.

Place general construction adhesive around connecting pipes on top of baluster.

One person should hold the top rail while the other person positions the baluster pipes into holes in top rail. Place rail to have $3/16$ " gap at each end. Use wooden shims to lock rail into position until glue hardens.

Note: Be sure glue does not squeeze out when positioning the balusters (see figure 8).



FIGURE 8

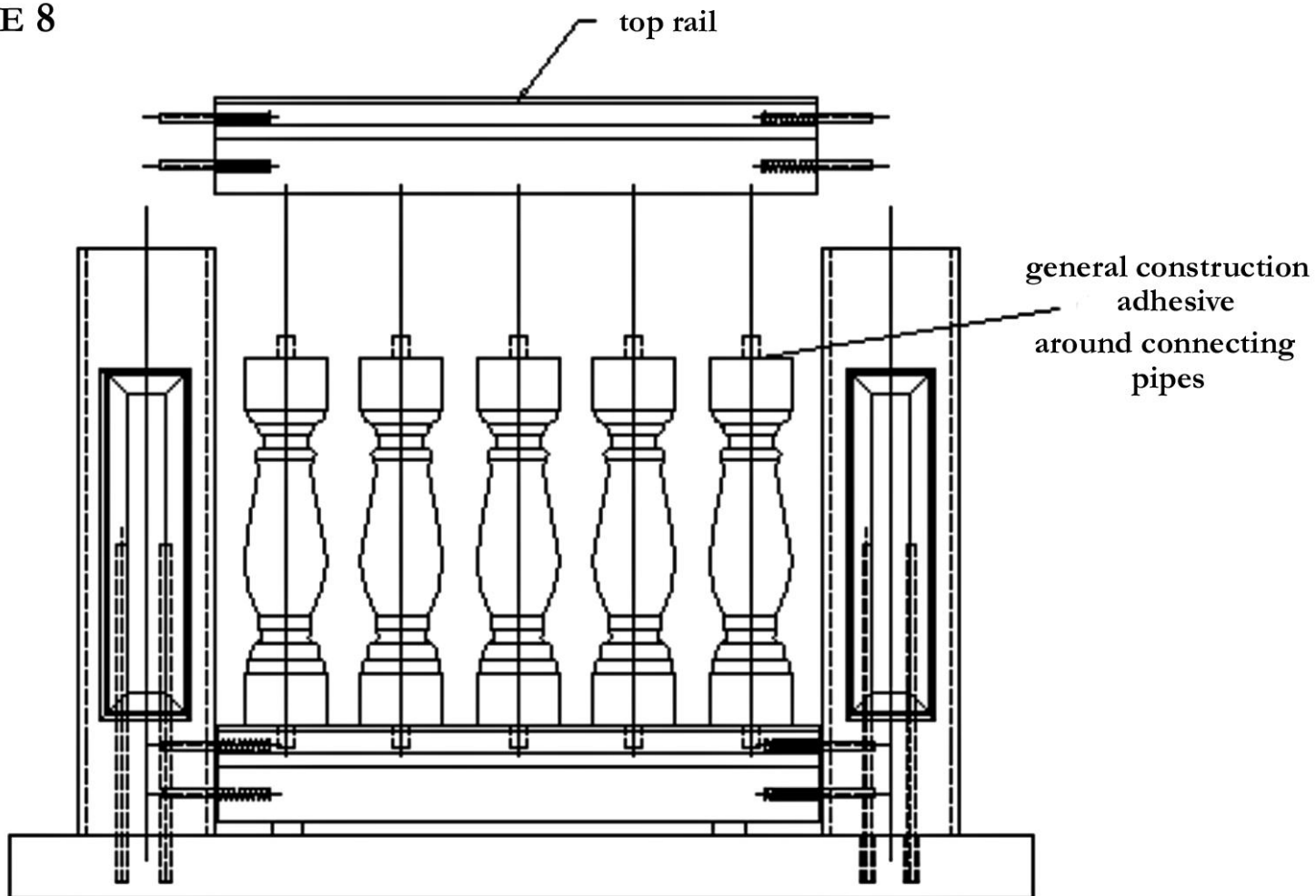

STEP 9: INSTALLATION OF NEWEL POST CAPS

Accessories required: general construction adhesive.

Use general construction adhesive to glue post caps on newel posts. Center cap over newel post. (see figure 9)

FIGURE 9

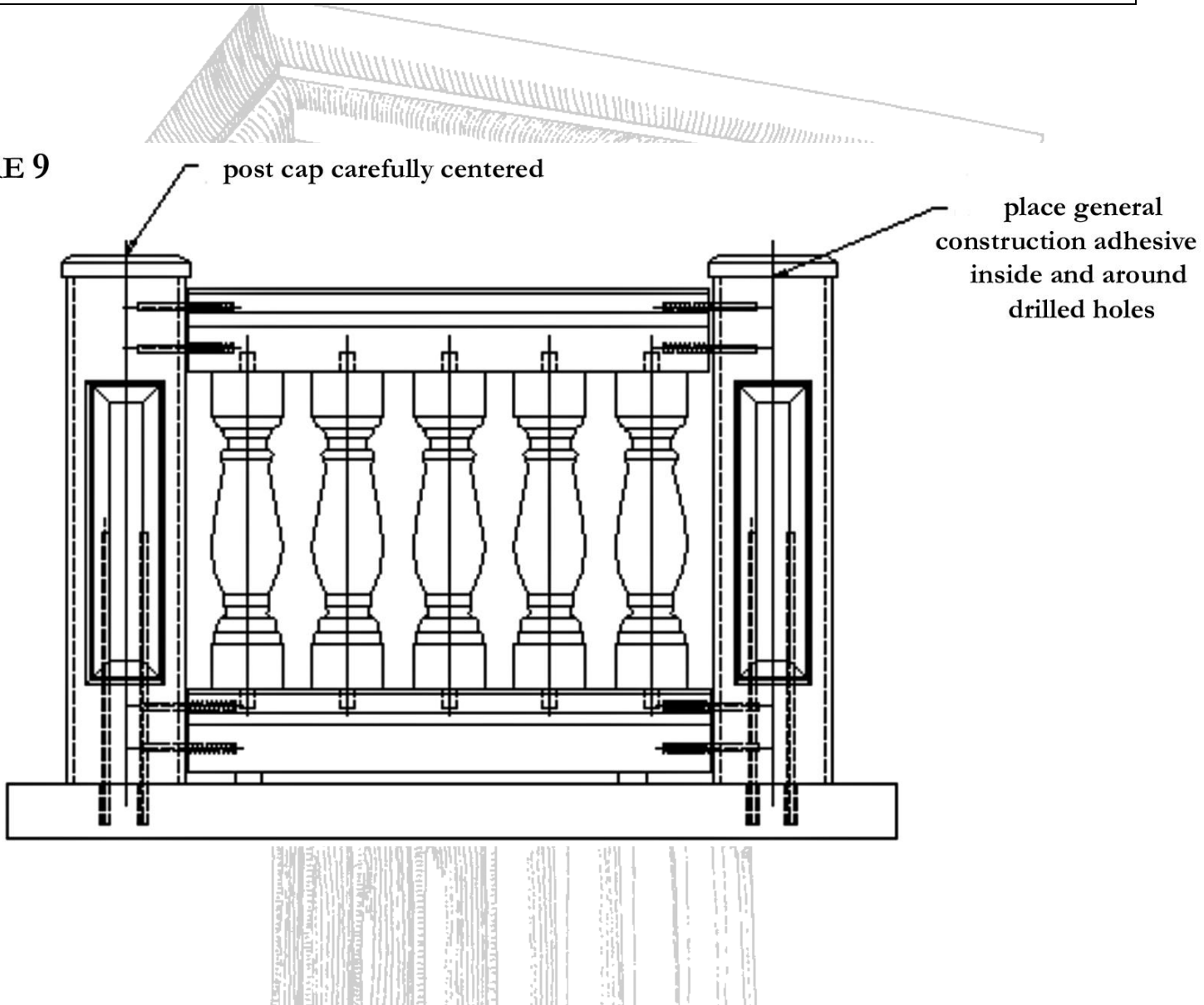

STEP 10: CLEANING

Accessories required: soap, brush, and fine grain sand paper.

Clean balustrade system only if needed. Use soap and brush.

Gently use fine grain sand paper if necessary.

STEP 11: CAULKING

Accessories required: matching color silicone caulk. We have found that **Sonneborn Sonalastic NP 1** works well with our Classic Stone products.

Important: Do not let any water to stay inside anywhere in the balustrade system, especially before freezing temperature. If installation is not complete before end of day, cover system with tarp to prevent rain and moisture infiltration.

Cover all joints, with silicone caulk, in the color to match the balustrade (see figure 10).

FIGURE 10

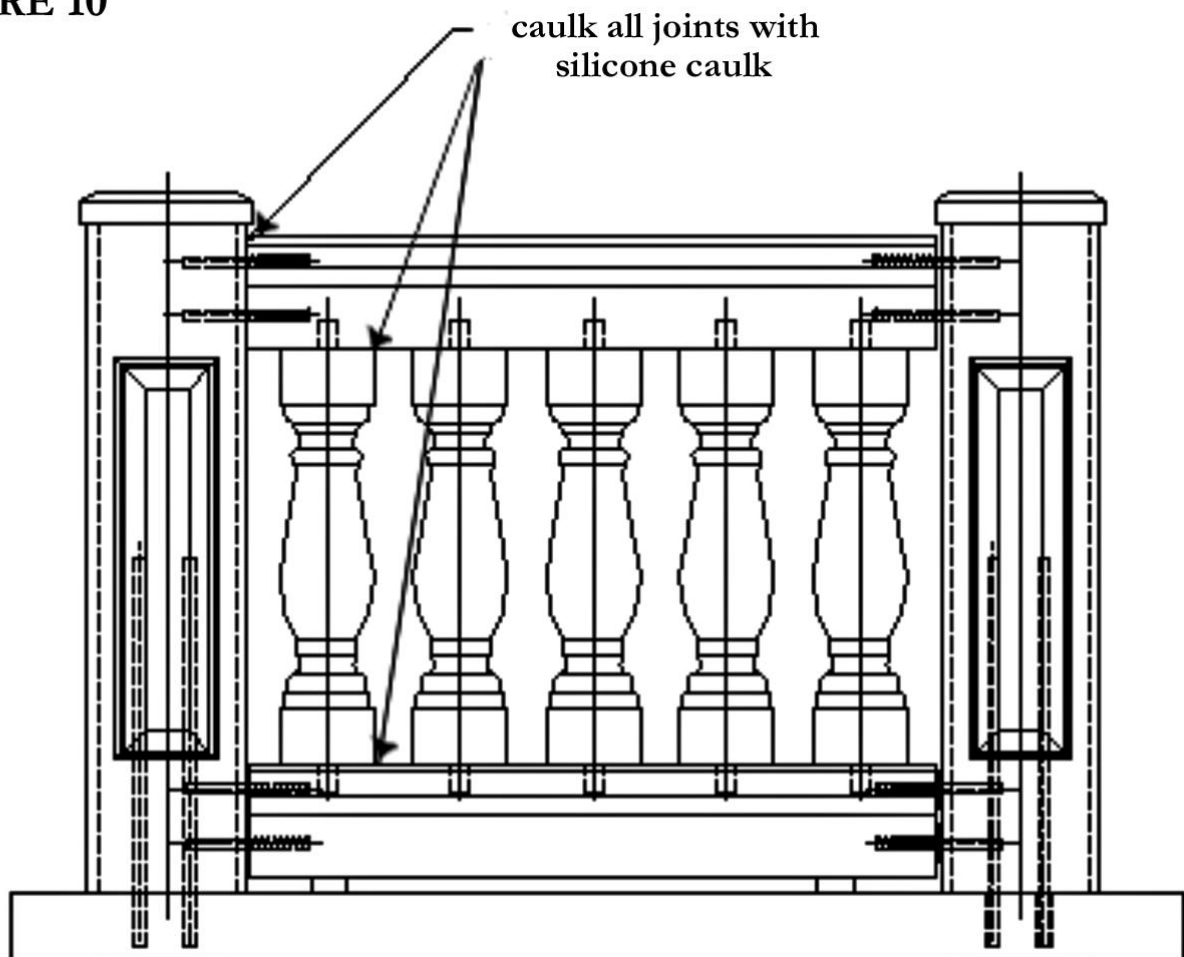

www.COLUMNS.com

CHADSWORTH INCORPORATED

277 NORTH FRONT STREET ▪ HISTORIC WILMINGTON, NC 28401 ▪ PHONE: 1.800.486.2118 ▪ FACSIMILE: 1.910.763.3191 ▪ E-MAIL: sales@columns.com