

# CHADSWORTH COLUMNS



BUILDER GRADE WOOD COLUMNS – INSTALL

## *CLASSIC & COLONIAL BUILDER GRADE WOOD COLUMNS*

Please carefully review all of the following instructions prior to installing your columns.

### ARRIVAL OF COLUMNS

- A. Inspection of all products is required upon delivery. Dry fitting is also recommended as soon as possible upon arrival. Damaged columns that are not refused or noted on the delivery receipt will not be honored.
- B. Typically, our paint-grade Classic & Colonial Builder Grade Wood Columns arrive unfinished. Upon arrival, paint all components on all surfaces with two (2) coats of oil-based primer, followed by two (2) coats of oil-based paint. Columns may need finish work prior to the application of oil-based primer & paint. Primer does not protect the column from moisture. **It is important to sand the column(s) thoroughly.** If a furniture finish is required, extensive sanding & priming is necessary. Brush painting is recommended for adequate coverage. **DO NOT USE LATEX PAINT.**
- C. Storage of your columns is **not** recommended. If storage is absolutely necessary, the columns must be stored in a dry, well-ventilated area that is protected from moisture. Improper storage may cause future problems and will void the warranty.

*CONTINUE TO INSTALLATION INSTRUCTIONS*

## INSTALLING THE COLUMNS

- A. Measure the overall height. If needed, trim the bottom of the column shaft. Be sure to take into account both the capitals and the bases for the overall height. Prime and paint exposed end grain prior to installation to avoid premature decay. {FIGURE 1}
- B. Determine the position of the plinth (or shaft if no base is used) by dropping a plumb line from the center of the beam to the deck. [FIGURE 2]  
This point on the deck will be the center of the plinth so that the top of the column shaft will align with the soffit. Keep in mind that the soffit must be centered over the column shaft – not off center. The soffit width should line up with the top diameter / width of the column shaft – not lining up with the capital edges.
- C. Follow instructions per base and capital materials used. (See each section for specific details)
- D. If possible, raise the soffit or porch slightly with a brace for easy installation of the columns. Slide the column assembly in place, and attach as noted in applicable sections.
- E. If the soffit cannot be raised, do not attach the base to the column. Install the base and/or capital (depending on material) first – then slide the remaining assembly in place and attach as specified in the appropriate sections.



FIGURE 1

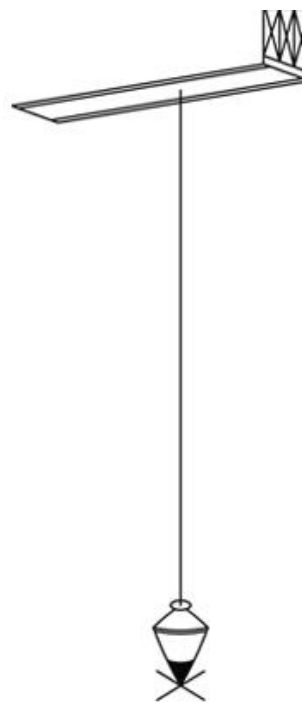

FIGURE 2

## SHAFT ASSEMBLY

- A. If you are using a Tuscan wooden or polyurethane capital, trim the top of the column shaft (top of section “K” on the diagram) so that the staves are of **equal length**. {FIGURE 3}
- If the shaft is trimmed to length, the ends should be sealed with a wood preservative or water sealer followed by two coats of oil-based primer and paint. This will help prevent moisture related cracks and premature decay or rot.
- B. If you are using a Decorative Capital, please see the Installation Instructions on our web site specifically for Decorative Capitals.
- C. Cut at the bottom of the column shaft to produce the proper length for your installation – unless this has been done in our factory for you.
- D. Apply caulking compound between the base and the shaft.
- E. Nail or screw the shaft to the base.
- F. For “Joining Split Columns, Capitals & Bases/Plinths” – see our separate installation instructions on our web site.

### IMPORTANT INFO

For **EXTERIOR** Installation: Ventilation is imperative for the longevity of your column. If column is not properly vented, the paint may peel and the column may crack. Your warranty would be voided if not properly vented.

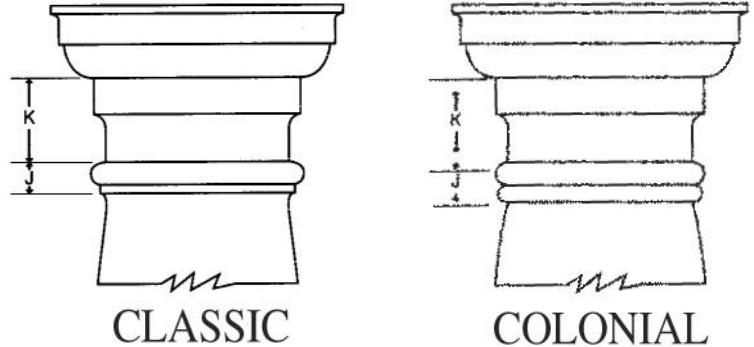
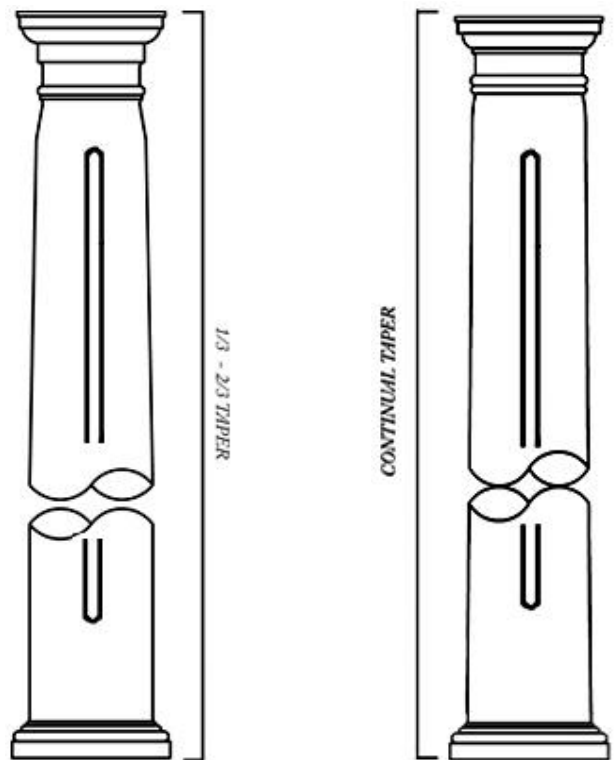

FIGURE 3



CLASSIC

Has a  
1/3 – 2/3 Taper

COLONIAL

Has a  
Continual Taper

## BASES

### ALUMINUM PLINTHS | [FIGURE 4]

- Install non-corrosive dowels into the floor. These dowels should fit in opposite corners of the plinth and prevent lateral movement.
- Level the plinth to the floor, if necessary, by scribing the plinth to the floor. Make sure that the original vent is maintained. This may necessitate enlarging the opening. **It is very important that the plinth is level before proceeding.**
- Attach the base moulding to the plinth by:
  - Turning the plinth and base moulding upside down.
  - Centering the plinth over the base moulding.
  - Using the pre-drilled holes in the plinth as a guide, drill  $3/16$ " holes into the base moulding.
  - Insert anchor flush with the bottom of the base moulding and screw through the plinth into the anchor using  $1-1/4$ " screws.
- Place the base assembly over the dowels.
- Proceed to base section.

### WOOD BASE MOULDING | [FIGURE 5]

- After assembling the base, place the shaft onto the base. Nail or screw shaft down at an angle into the base.
- Use paintable silicone sealant to seal the joint between the shaft and the base.

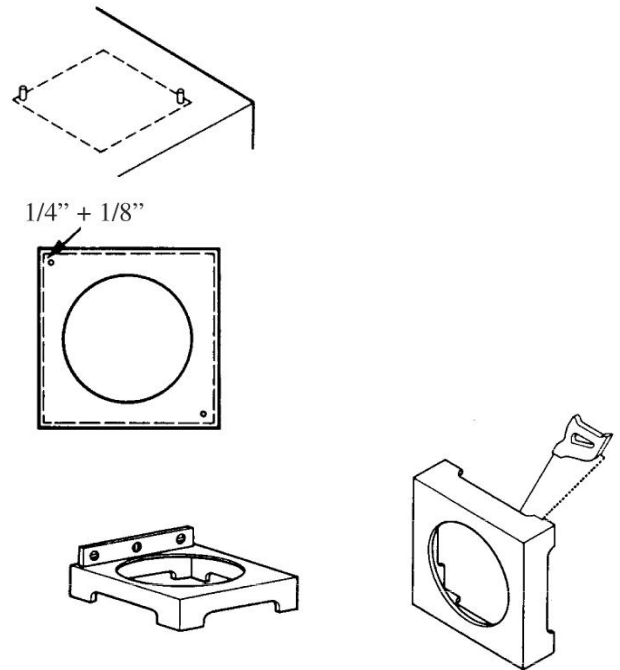

FIGURE 4

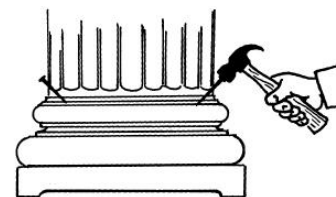
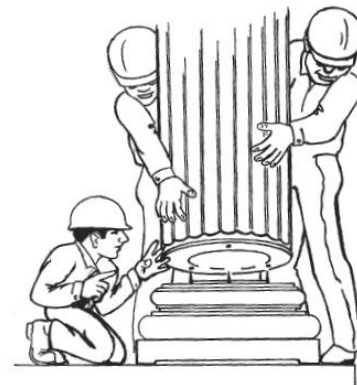

FIGURE 5

## POLYURETHANE BASE MOULDING AND PLINTH (One Unit)

- Install non-corrosive dowels into the floor. These dowels should be in the opposite corners of the plinth and prevent lateral movement. Use a template to mark the location of the dowel placement in the bottom of the polyurethane base and the flooring. Place the polyurethane base into the proper position on the floor to make sure the dowels are aligned.
- Level the plinth (if necessary) by cribbing it to the floor. **It is important that the plinth is perfectly level before proceeding.**
- Drill holes into the plinth and screw from the bottom of the plinth up into the bottom of the column shaft. For columns with 14" diameters and larger, drill holes through the shaft into the base.
- Place over the dowels.
- Place the column shaft on top of the base.
- Nail or screw shaft down at an angle to base.
- Use a paintable silicone sealant to seal the joint between the column shaft and the base.

## POLYURETHANE OR WOOD TUSCAN CAPITALS | [FIGURE 6]

- (For Exterior Applications): Install flashing material over the capital by bending metal over the edge of the capital. **Do not cover the opening in the capital.**
- Nail or screw the capital to the column shaft.
- Nail or screw the capital to the soffit.
- Use a paintable silicone sealant to seal the joint between the soffit & flashing, and between the capital & the shaft.

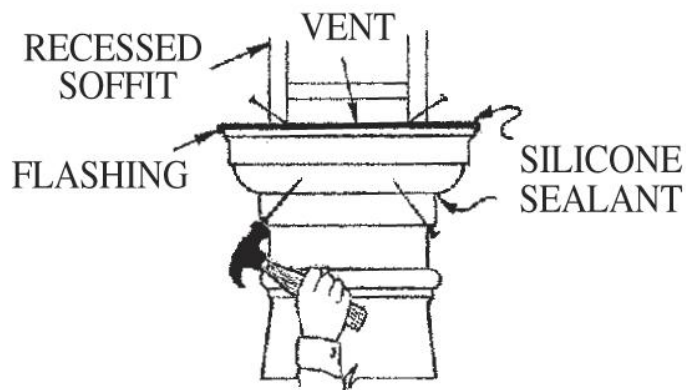
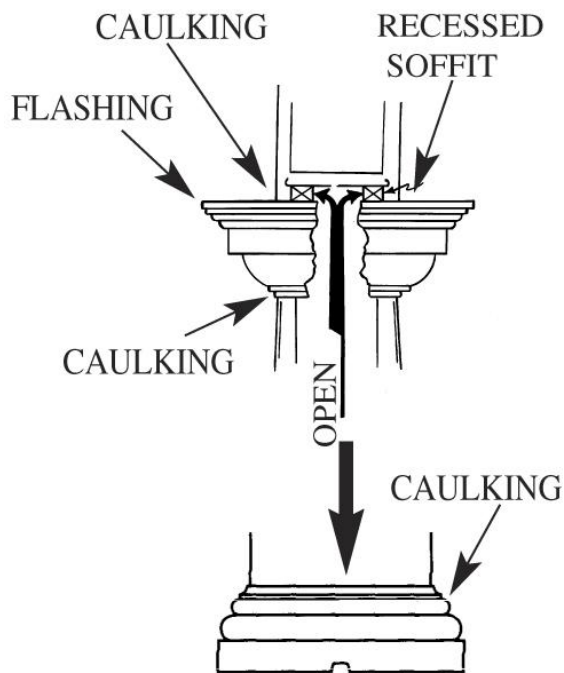

FIGURE 6

**Always be certain that the load is evenly distributed over the bearing surface of the column.**

### FINISHING GUIDELINES

A. Chadsworth recommends using oil-based exterior grade paint on all components. Oil-based paints provide the best coverage and sealing of hardwoods.

\*\*\* If oil-based paint is not available in your area, please call to discuss your options with a Chadsworth representative. \*\*\*

B. Any nail holes, small cracks and/or dents must be filled with wood filler and sanded smoothly with 100-grit sandpaper. (Re-prime and paint immediately after).

C. After installation and caulking is complete, one last coat of paint is recommended.

D. If a furniture-grade finish is desired, additional sanding and priming will be required prior to painting.

### GENERAL NOTES

E. Please see your building code for uplift protection requirements. Threaded rod or strap tie down may be required in some high wind areas.

F. Always use non-corrosive hardware to avoid rusting.

G. All exterior columns must be properly vented. Ventilation must be provided at the top of the column by a recessed soffit. Polyurethane capitals are vented. Ventilation is provided at the bottom of the column by the polyurethane base or aluminum plinth. **This ventilation must be maintained at all times for exterior columns.** See diagram on the next page for details. Venting ensures the longevity of your column. Failure to do so may cause splitting, paint peeling, and will void the warranty.

\*\*\* See our split column, pilaster and/or decorative capital installation if needed. \*\*\*

## VENTILATION INSTRUCTIONS

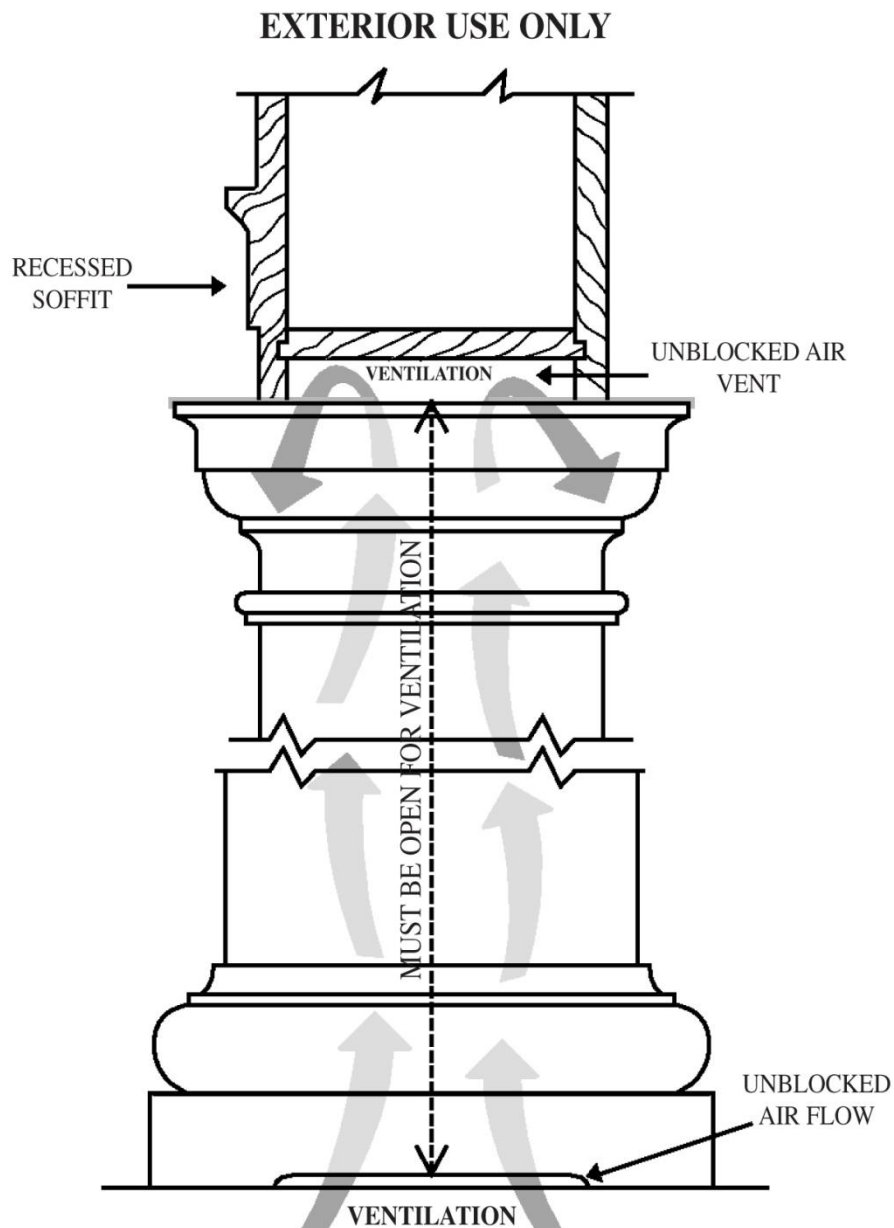

Ventilation must be provided at the top and the bottom of the columns. Air flow must move through the center of the column, capital and flashing into a recessed soffit and through the base and plinth.

The installing contractor must provide this ventilation with a recessed soffit and open plinth for the warranty of the column.



## INHERENT CHARACTERISTICS OF WOOD

This advisory concerns prevention of dimensional problems in architectural woodwork products as the result of uncontrolled relative humidity. It is further intended as a reminder of the natural dimensional properties of wood and wood-based products and of the routine and necessary care and responsibilities which must be assumed by those involved.

For centuries, wood has served as a successful material for architectural woodwork, and as history has shown wood products perform with complete satisfaction when correctly designed and used. Problems directly or indirectly attributed to dimensional change of the wood are usually, in fact, the result of faulty design, or improper humidity conditions during site storage, installation, or use.

Wood is a hygroscopic material, and under normal use conditions all wood products contain some moisture. Wood readily exchanges this molecular moisture with the water vapor in the surrounding atmosphere according to the existing relative humidity. In high humidity, wood picks up moisture and swells; in low humidity wood releases moisture and shrinks. As normal minor fluctuations in humidity occur, the resulting dimensional response in properly designed construction will be insignificant. To avoid problems, it is recommended that relative humidity be maintained with the range of 25%-55%. Uncontrolled extremes (below 20% or above 80% relative humidity) can likely cause problems.

Together with proper design, fabrication, and installation, humidity control is obviously the important factor in preventing dimensional change problems.

Architectural woodwork products are manufactured as designed from wood that has been kiln dried to an appropriate average moisture content and maintained at this condition up to the time of delivery. Subsequent dimensional change in wood is and always has been an inherent natural property of wood. These changes cannot be the responsibility of the manufacturer or products made from it. Specifically:

- Responsibility for dimensional change problems in wood products resulting from improper design rests with the designer/architect/specifier.
- Responsibility for dimensional change problems in wood products resulting from improper relative humidity exposure during site storage and installation rests with the contractor.
- Responsibility for dimensional change problems in wood products resulting from humidity extremes after occupancy rests with engineering and maintenance.

It is normal for wood to expand or contract with changes in atmospheric conditions. Wood will adjust to climate.

## VARIATIONS IN NATURAL WOOD PRODUCTS

Wood is a natural material, with variations in color, texture and figure. These variations are influenced by the natural growing process and are uncontrollable by the woodworker. The color of wood within a tree varies between the “sapwood” (the outer layers of the tree which continue to transport sap), which is usually lighter in color than the “heartwood” (the inner layers in which the cells have become filled with natural deposits). Various species produce different grain patterns (figures), which will influence the selection process. There will be variations of grain patterns with any selected species. The architectural woodworker cannot select solid lumber cuttings within a species by grain and color in the same manner in which the veneers may be selected. Color, texture, and grain variations will occur in the finest architectural woodworking.

Reprinted with permission as published by the Architectural Woodwork Institute, Reston, VA