

12 x 12 Flat Top Pergola

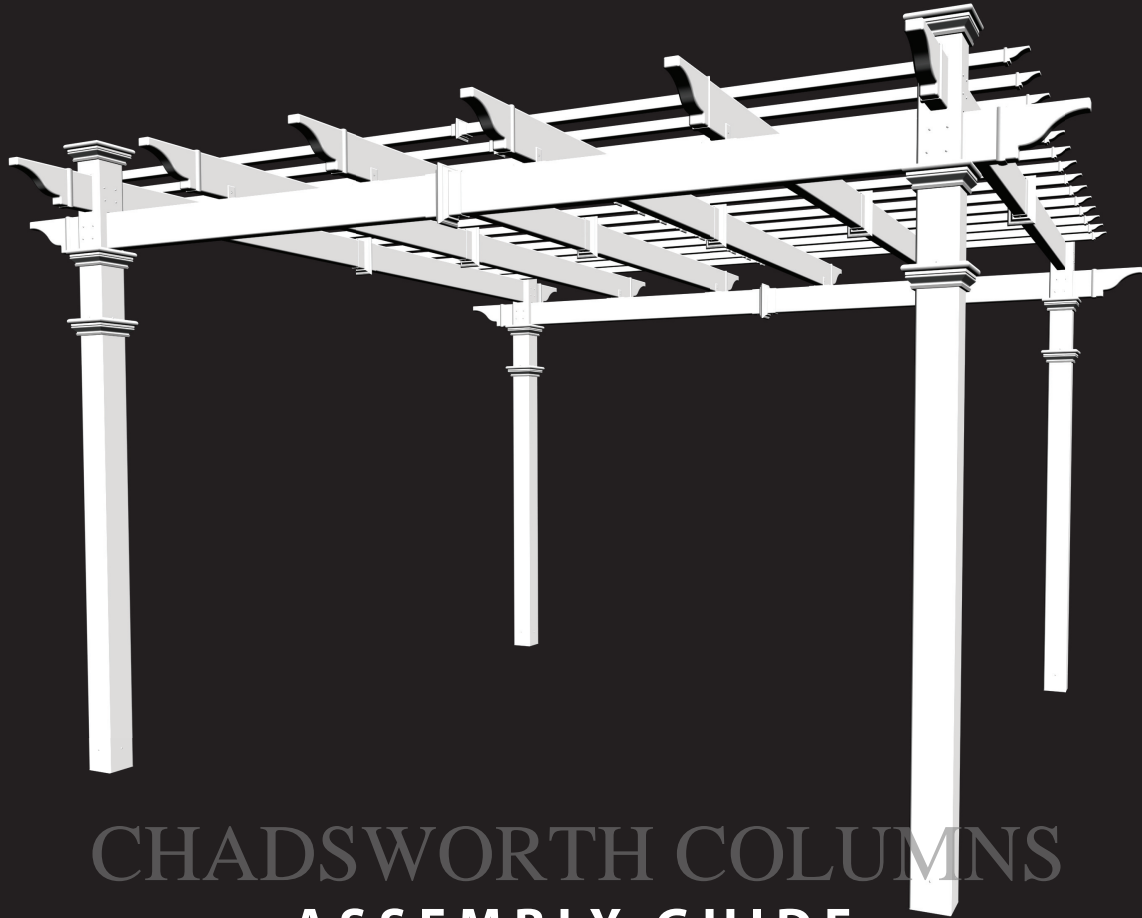

CHADSWORTH COLUMNS ASSEMBLY GUIDE

Model: **Regency**

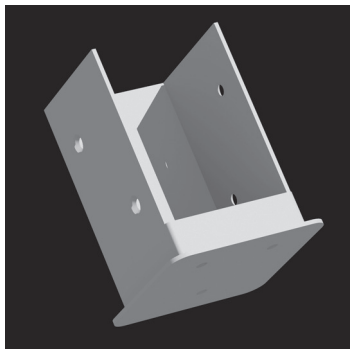

OPTIONAL ACCESSORY

- Bolt Down Bracket Kit (*4 for Pergola*)

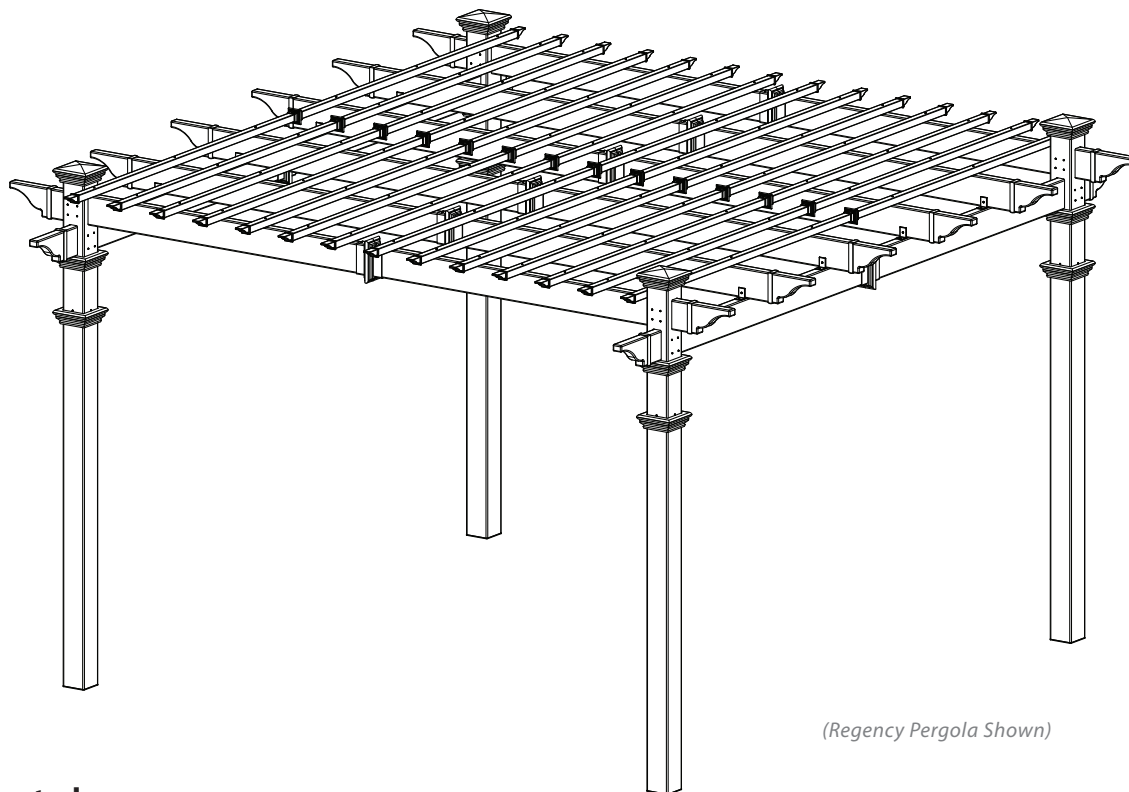

Table of Contents

	PAGE
12 x 12 Flat Top Pergola	
Introduction & Overview.....	3
Pergola Materials Overview.....	4
Pergola Materials Breakdown.....	5
Pergola Additional Materials List.....	6
Wood Post Layout & Installation for In-Ground Application.....	7
Wood Post Layout & Installation using Bolt Down Post Brackets for Concrete or Wood Surface.....	8
Vinyl Column Assembly and Installation Over Wood Posts.....	9
Vinyl Beam Assembly.....	10
Vinyl Rafter Assembly.....	11
Vinyl Beams & Rafter Placement.....	12
Fastening Vinyl Beams, Rafters & Caps.....	13
Shade Slats Installation.....	14

CHADSWORTH COLUMNS

Introduction & Overview



(Regency Pergola Shown)

Getting Started

First off, allow us to say thank you for the investment you have made in one of our fine pergola kits. This kit is designed to be assembled and installed ideally by two people with basic carpentry knowledge and tools. Do not attempt alone, especially during the installation stage. Should you decide to moderately modify the dimensions of your pergola from the standard kit size, a circular saw with a sharp fine-tooth blade is all that is needed to cut, shorten or modify the vinyl components. When assembling components place on a non-abrasive surface (ie: shipping box) to avoid scratching. We recommend a 15' x 15' area for unobstructed assembling. You should not need to use excessive force when assembling any components.

Planning & Preparing

The Regency Pergola is made to stand independent of your home and you can either locate it near your house or let it stand alone in the garden. By keeping it unattached from your home you will not have to deal with moving existing gutters or matching eave heights. If you plan to build your pergola close to the house, please keep the outer extremities of the pergola a minimum of 4 inches back from your eaves.

What looks like the toughest part of this project is actually the easiest, the graceful, solid-looking columns. We've designed these columns to simply be slipped over treated 4x4 wood posts that are either embedded in concrete or directly mounted to a concrete or wood surface using our bolt down brackets. See pages 7, 8 and 9 for more details.

It is critical before you start that you consider the current slope of elevation where the pergola is planned - if there is any. Also utility or sprinkler line location is important to identify prior to excavating holes if necessary. You should also check to verify local building codes, ordinances, neighbourhood covenants, or height restrictions regarding this type of structure.

Restriction of Use

This product is not designed to carry additional weight loads such as swings, people or other objects.

Regency Pergola Materials Overview

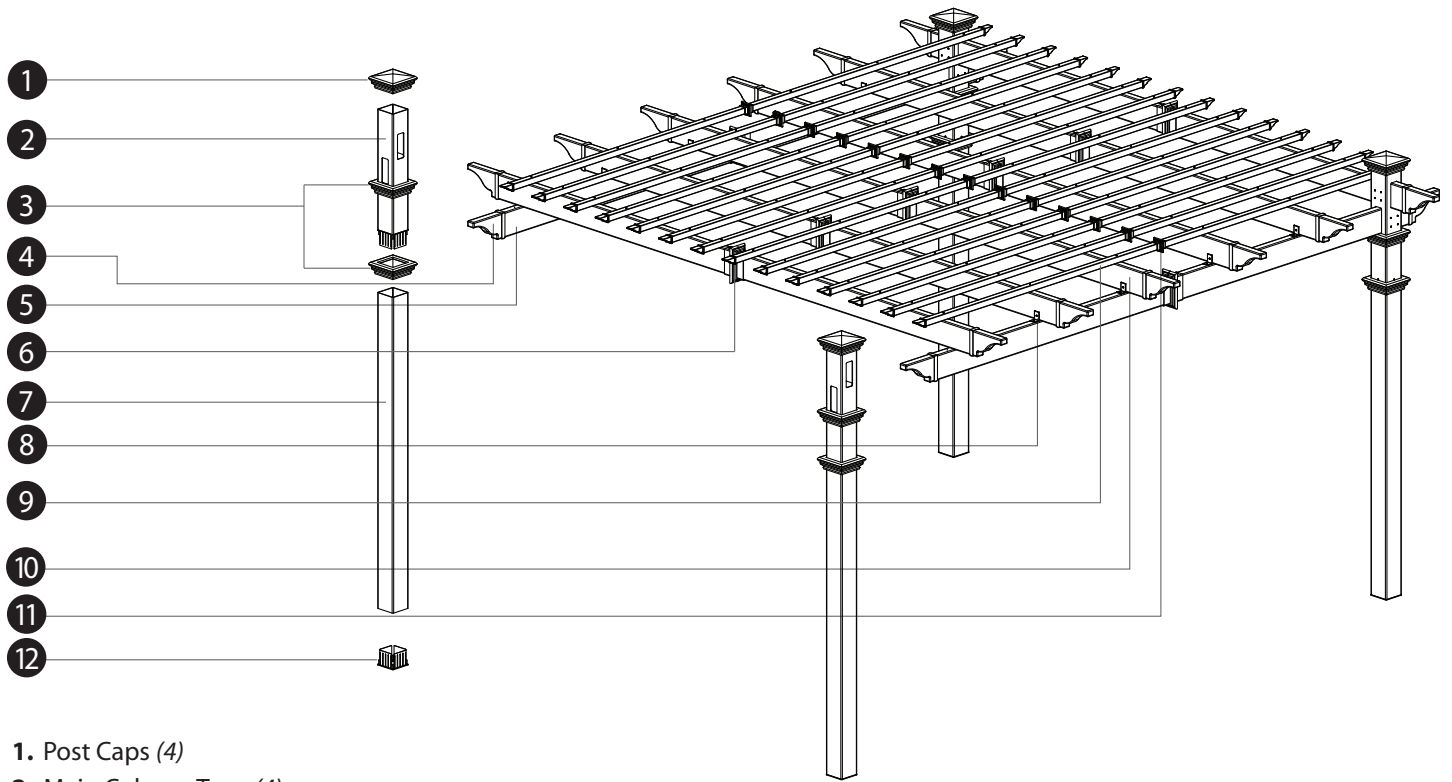

- 1. Post Caps (4)
- 2. Main Column Tops (4)
- 3. Post Trims (8)
- 4. Rafter & Beam Decorative End Caps (16)
- 5. Main Support Beams (4)
- 6. Beam & Rafter Joiners (8)
- 7. Main Column Bottoms (4)
- 8. Rafter Brackets (8)
- 9. Shade Slats (28)
- 10. Rafters (12)
- 11. Shade Slat Joiners (14)
- 12. One Way 4"x4" Internal Wood Post Guide (4)

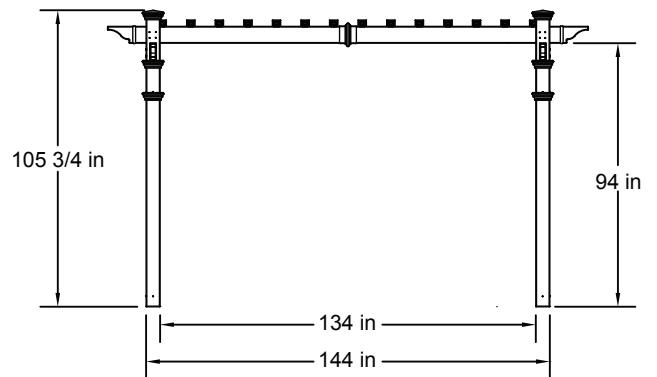
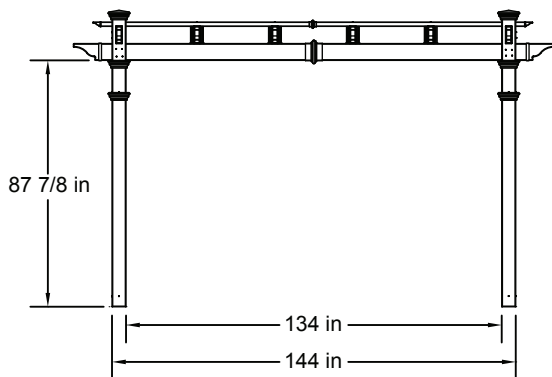
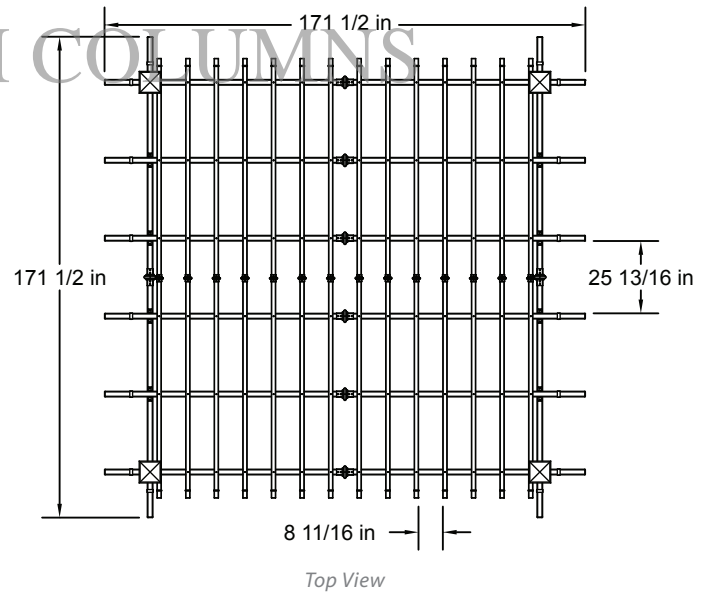

Regency Pergola Materials Breakdown

Check Boxes (Total of 6) for These Contents

- 1. Main Column Bottoms (4)
- 2. Main Column Tops (4)
- 3. Beam & Rafter Joiners (8)
- 4. One Way 4"x4" Internal Wood Post Guide (4)
- 5. Shade Slat Joiners (14)
- 6. Post Caps (4)
- 7. Post Trims (8)
- 8. Rafter & Beam Decorative End Caps (16)
- 9. Rafter Brackets (8)
- 10. Main Support Beams (4)
- 11. Rafters (12)
- 12. Shade Slats (28)
- 13. Rafter Hanger (6)*

(*) May be disposed of when installing the Regency Pergola.

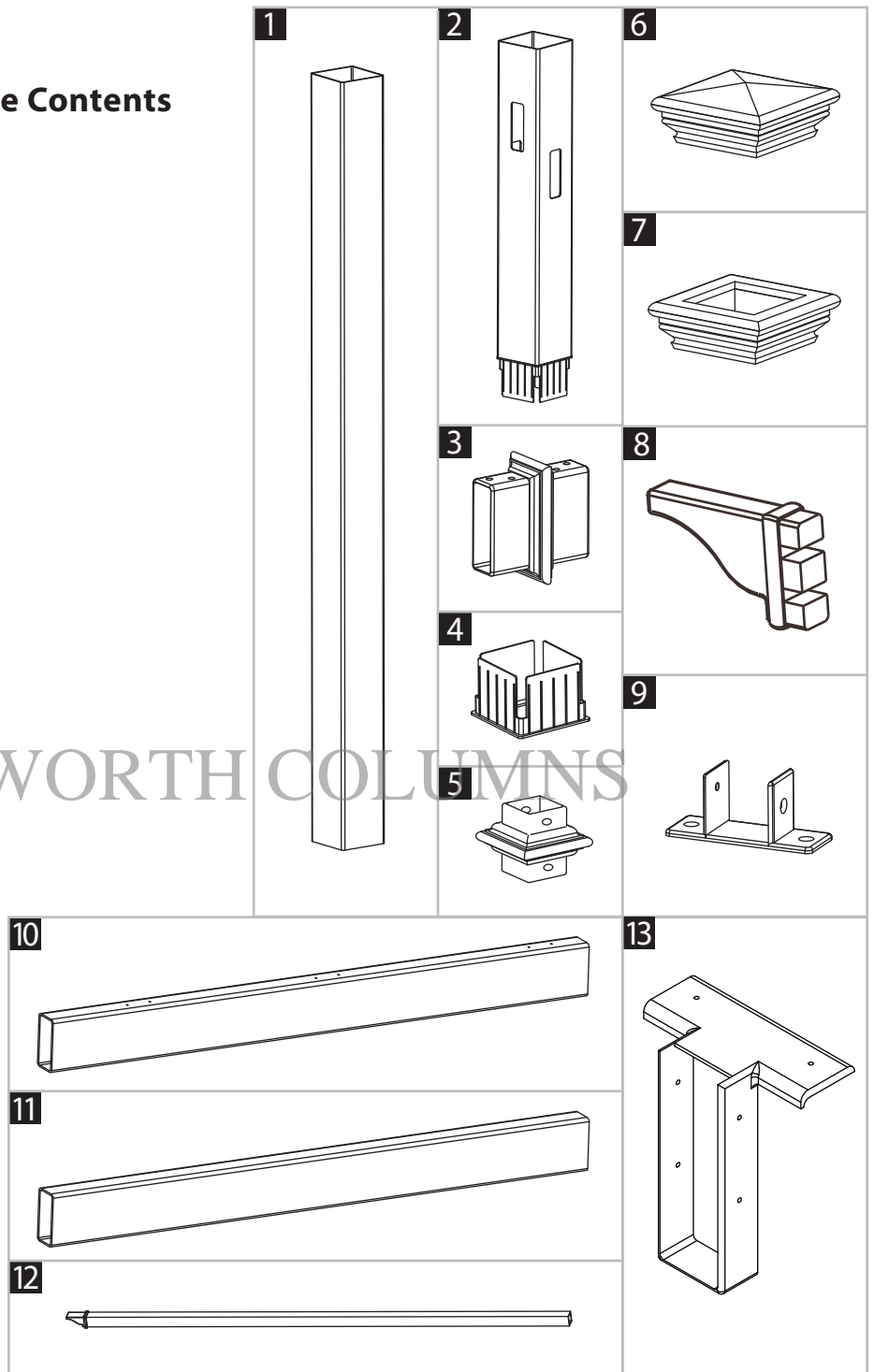

Not to Scale

Pergola Additional Materials List

Hardware *(in plastic bag)*

NOTE: WE HAVE INCLUDED 10% EXTRA SCREWS BEYOND WHAT IS IDENTIFIED BELOW.

All Screws Included with this Kit are Self-Auguring.

- A.** Vinyl Weld Glue (2)
- B.** 2 1/2" Self-Auguring Stainless Steel Screws (16)
(to lock vinyl column and wood post together at bottom of each post)
- C.** 2 1/2" Self-Auguring Stainless Steel Screws (16) *(to lock vinyl column and wood post together at top of each post just above trim cap)*
- D.** 4" Self-Auguring Stainless Steel Screws (64) *(to lock the intersection of beams and first rafters with vinyl columns)*
- E.** 1 1/2" Self-Auguring Stainless Steel Screws (48) *(joiner screws)*
- F.** 5/8" Self-Auguring Stainless Steel Screws (40) *(for rafter brackets and/or rafter hanger)*
- G.** 3" Self-Auguring Stainless Steel Screws (84) *(for shade slats)*
- H.** 1/8" x 2" Drill Bit (1) *(to pre-drill holes on wall when installing the Freemont pergola)*

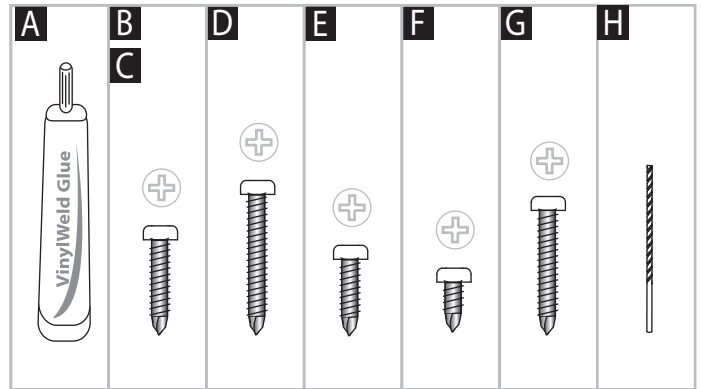

Extra Materials You will Need

If Mounting Pergola on Concrete or Wood Deck

- I.** 4x4x7 Pressure-Treated Wood Posts (4) *(purchase at local building center)*
- K.** 4x4 Bolt Down Bracket Kit

If Mounting Pergola in Ground

- J.** 4x4x10 Pressure-Treated Wood Posts (4) *(purchase at local building center)*
- L.** Concrete Ready Mix (4) *(purchase at local building center)*

Rafter/ Beam Support (Required)

- M.** 2x6x12 Pressure-Treated Posts (8) *(purchase at local building center)*

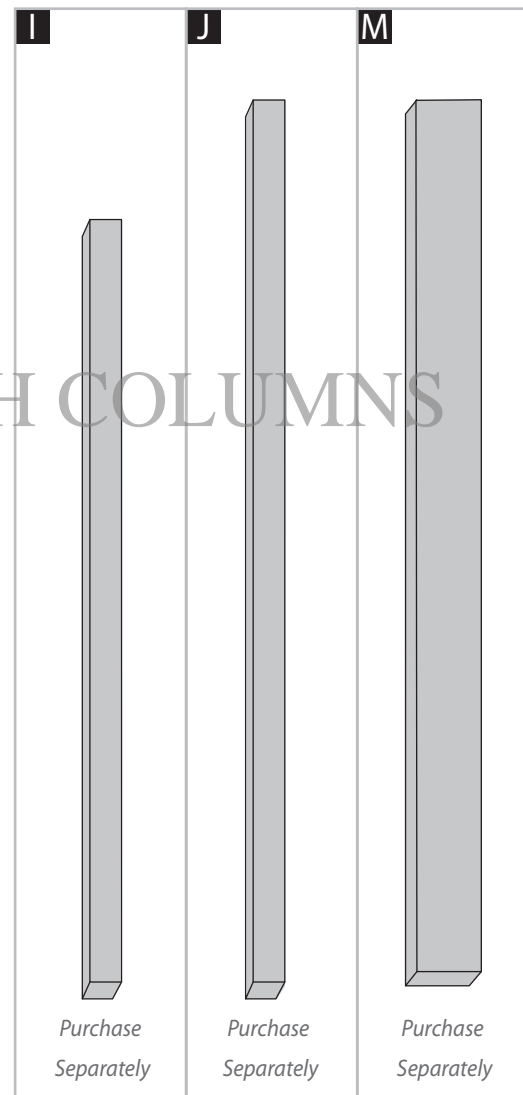

Tools You Will Need

- Level
- Hammer
- Tape Measure
- String Line
- Wood Stakes (4) *(temporary support for string line)*
- Step Ladders (2)
- Cordless Drill

Tools You May Need

- Circular Saw with Fine Tooth Blade
- Framing Level
- Framing Square

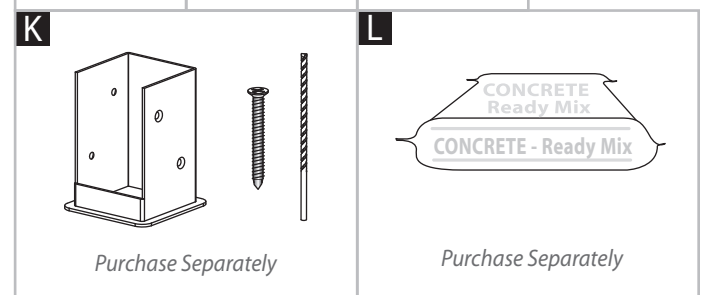

Wood Post Layout & Installation for In-Ground Application

This pergola can also be installed on a pre-existing wood or concrete surface using our bolt down bracket system with a 4x4 wood post (sold separately). See page eight for more details.

Post location and placement is the most critical step in the overall installation process. Please double check for the possibility of any underground utilities such as sprinkler, gas or telephone lines.

STEP ONE

Measure and mark out the location of the pergola posts using string line and temporary wood stakes. Diagonal distances must be the same to ensure a square installation. Adjust string lines accordingly. The inside corner of the string lines will be the post location.

Please Note:

Should you decide to moderately modify the dimensions of your pergola from the standard kit size, a circular saw with a sharp fine-tooth blade is all that you need to cut, shorten or modify the vinyl components.

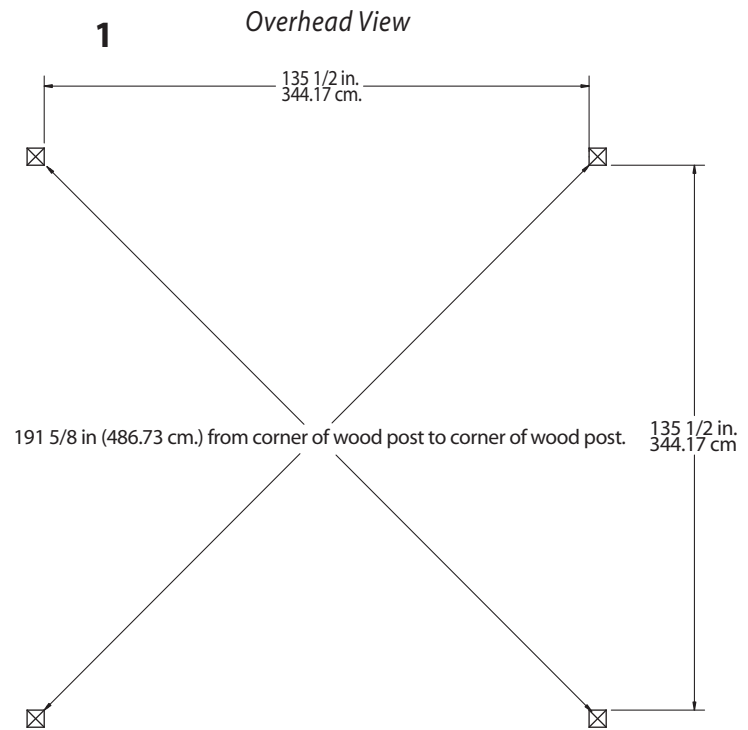

STEP TWO

Install Wood Supporting Posts Directly into the Ground

1

After you have determined where the posts will be located, excavate 10" diameter x 36" deep post holes.

2

After holes are dug and cleaned, place the 4x4 wood post into a hole ensuring it's level and square to string lines. The final post height should be no more than 84" out of the ground. If a post is higher because of obstructed excavation of footings, please cut down in height accordingly.

3

Fill the vacant hole with pre-mixed concrete all the way to within 3" of the top of the hole.

4

Repeat for all four posts.

Please Note:

Some 4x4 pressure treated posts can be larger than 3 1/2 x 3 1/2 square due to twisting or cracking. We have allowed a tolerance for this in the internal one way and two way 4x4 wood post guides (see page 8). However in extreme cases you may need to shave down the top of the 4x4 wood post slightly to get the vinyl post started over the wood post. Before installing your wood posts in the ground, please check to confirm this and correct at this stage if necessary.

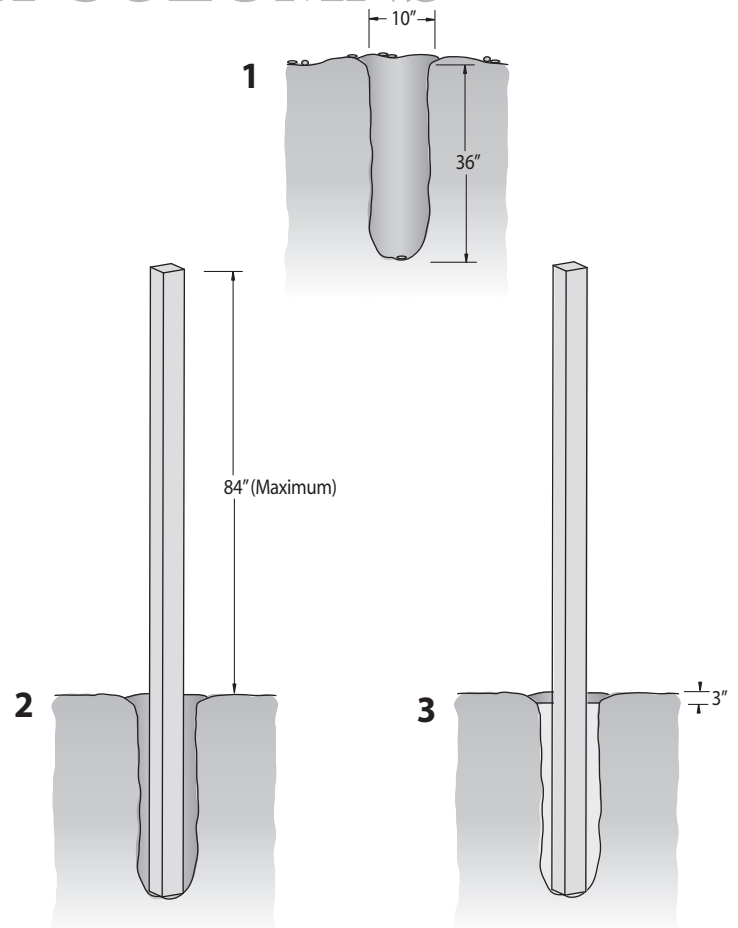

OPTIONAL STEP

Wood Post Layout & Installation Using Bolt Down Brackets for Concrete or Wood Surface

1

Measure and mark out the location of the pergola posts using string or chalk line. Diagonal distances must be the same to ensure a square installation. Adjust string lines accordingly. The inside corner of the string lines will be the post location.

2

Mark out the location of bolt down brackets accordingly using the base of the bracket accordingly.

3

Using the 5/32" masonry drill bit included in your bolt down bracket kit, drill 3" deep holes to allow installation of 2 1/2 concrete screws included in your kit.

4

Proceed to install three 2 1/2 concrete screws into the bottom base of the bolt down bracket.

Please Note:

Concrete patios generally have sloped surface for water run-off. If this is the case, when you secure the bolt down bracket to the concrete, the bracket may be at an angle. This can be corrected for level using galvanized steel washers (not provided), acting as shims underneath the base to level - **VERY IMPORTANT OR PERGOLA BEAMS AND RAFTERS WILL NOT BE LEVEL.**

5

With the four post brackets installed plumb, proceed to set the 4x4 x7' wood post in place. Secure using the same concrete screws included in the kit. Repeat for all 4 posts.

6

Posts should not exceed 84" in height. Please cut down in height if necessary.

Please Note:

Some 4x4 pressure treated wood posts can be larger than 3 1/2 x 3 1/2 square due to twisting or cracking. We have allowed a tolerance for this in the post brackets and the internal one way and two way 4x4 wood post guides. However in extreme cases, you may need to shave down the end of your 4x4 wood post slightly to allow access.

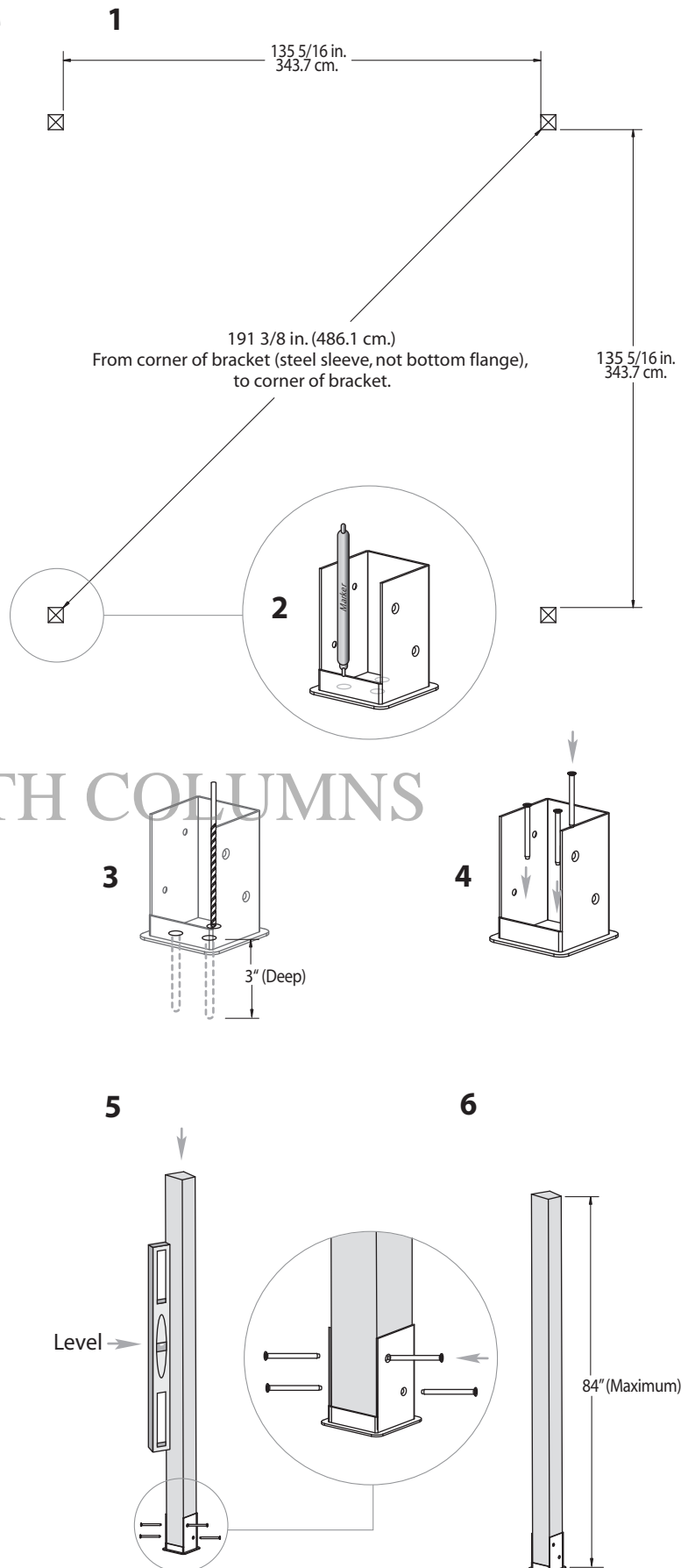

STEP THREE

Vinyl Column Assembly & Installation Over Wood Posts

1

Using the vinyl weld glue, insert the One Way 4"x4" Internal Wood Post Guide in the one end of the main column posts. This step is only applicable if your wood 4x4 post are embedded into the ground. If your pergola is going to be installed on wood or concrete surface, please dispose of these four pieces.

2

Using a step ladder, guide the bottom vinyl columns over the wood 4x4 posts.

3

Using a step ladder guide the top vinyl columns over the wood 4x4 posts.

Please Note:

Ensure that holes at top of column are orientated correctly for future beam and rafter placement. See diagram at top of next page.

4

Connect the bottom and top vinyl column by using vinyl weld and sliding together. **Please Note:** Vinyl Weld Glue has about a sixty second cure time and about a 20 minute dry time.

5

Slide the bottom post trim into position to cover the joint on the column.

6

Slide the top post trim into approximate position just below the bottom routed hole on the bottom of the top vinyl column assembly.

7

Final adjust post heights accordingly to ensure future level installation of beams and rafters as necessary. If slope is severe causing a height difference between the posts, you may need to trim down the top of two or more of your vinyl columns as necessary.

8

Secure the vinyl columns to the wood posts using 4 – 2 1/2" self-auguring stainless steel screws at 8" up from the base of the posts, and 4 – 2 1/2" self-auguring stainless steel screws just above the trim cap as illustrated. This will prevent possible uplift during high winds, etc.

*Ensure that holes at top of column are orientated correctly for future beam and rafter placement.

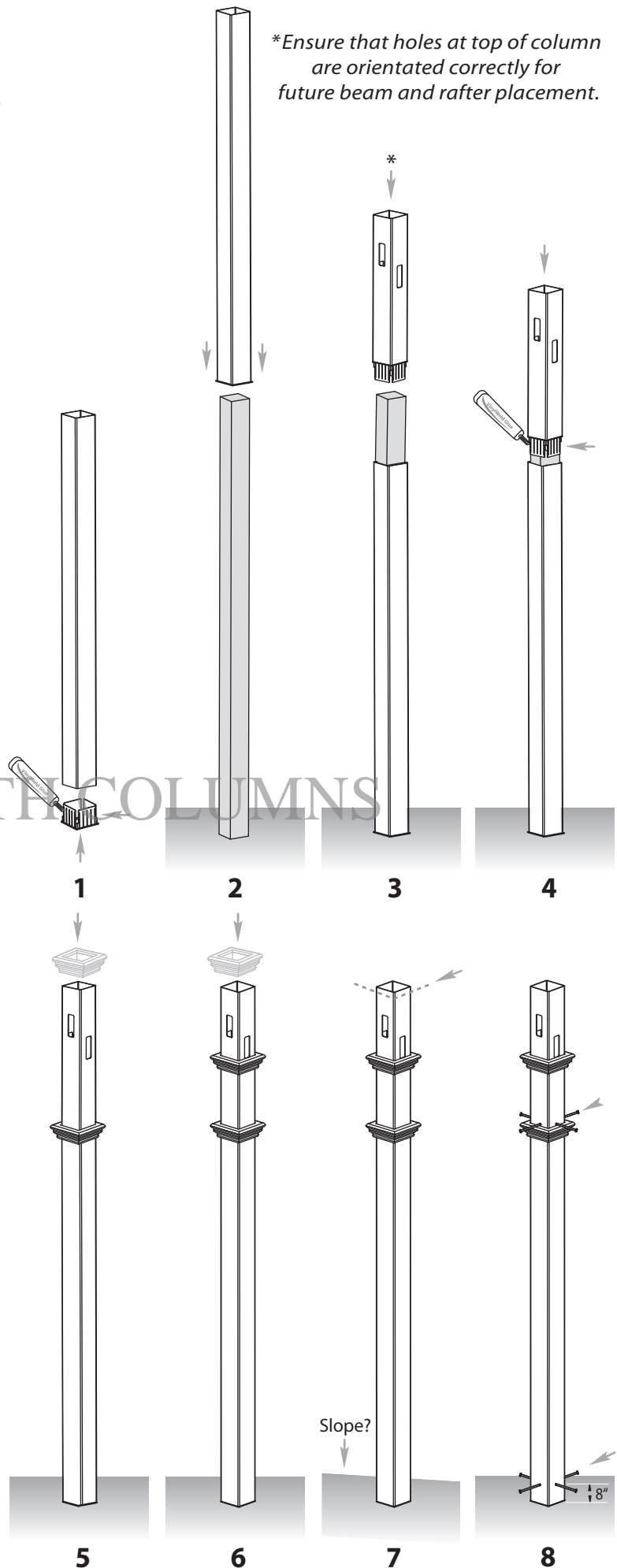

At this stage, the columns should be properly installed as per the following illustration, with the columns 134" in. (340.4 cm) apart. Also, notice that the holes at the top of each post should be facing the same direction.

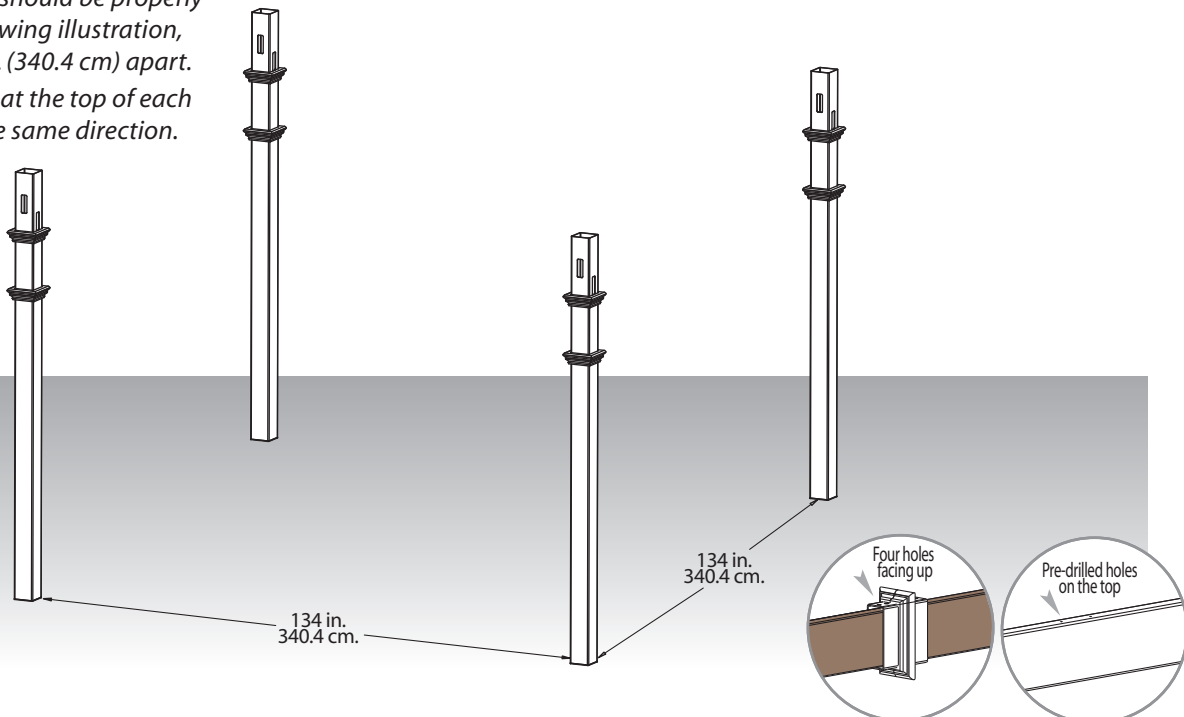

STEP FOUR

Vinyl Beam Assembly

1

Insert one 2x6x12 pressure treated wood into a beam section followed by the joiner and another beam section.

Critical Note:

Note the location of the pre-drilled holes on beams. As pictured aside, the further distanced holes need to mate together inside the beam joiner. this is critical to ensure equal spacing of your rafters.

2

Temporarily insert the pergola ends into both end of the beam as shown aside. Due to the length variation in wood, this will ensure that the pergola ends will go on perfectly.

Please Note:

If there is a gap between the pergola end and beam, remove 2x6 wood and trim down the wood beam appropriately.

3

Install the rafter brackets to the main beams using 5/8" screws. Only attach four brackets to the beam as shown. Follow the pre-drilled holes to identify locations.

4

Screw the joiner to vinyl beams and wood insert using 1 1/2" screws.

5

Remove and set aside pergola ends for the time being. Repeat steps 1 to 4 for second beam.

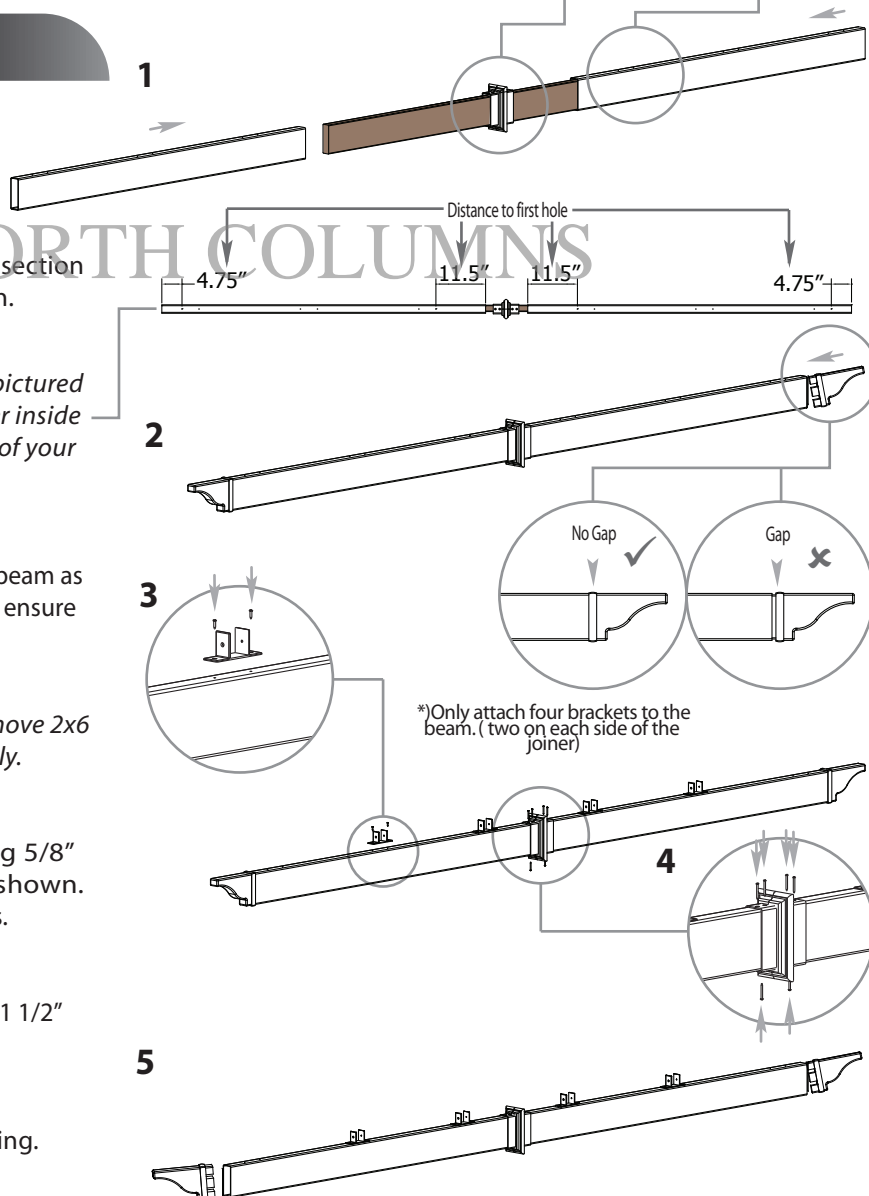

STEP FIVE

Vinyl Rafter Assembly

1

Insert one 2x6x12 pressure treated wood into a rafter section followed by the joiner and another rafter section.

2

Temporarily insert the pergola ends into both end of the rafter as shown aside. Due to the length variation in wood, this will ensure that the pergola ends will go on perfectly.

Please Note:

If there is a gap between the pergola end and rafter, remove 2x6 wood and trim down wood beam appropriately.

3

Screw the joiner to vinyl rafters and wood insert using 1 1/2" screws.

4

Remove and set aside pergola ends for the time being. Repeat steps 1 to 3 for the remainder of the rafters.

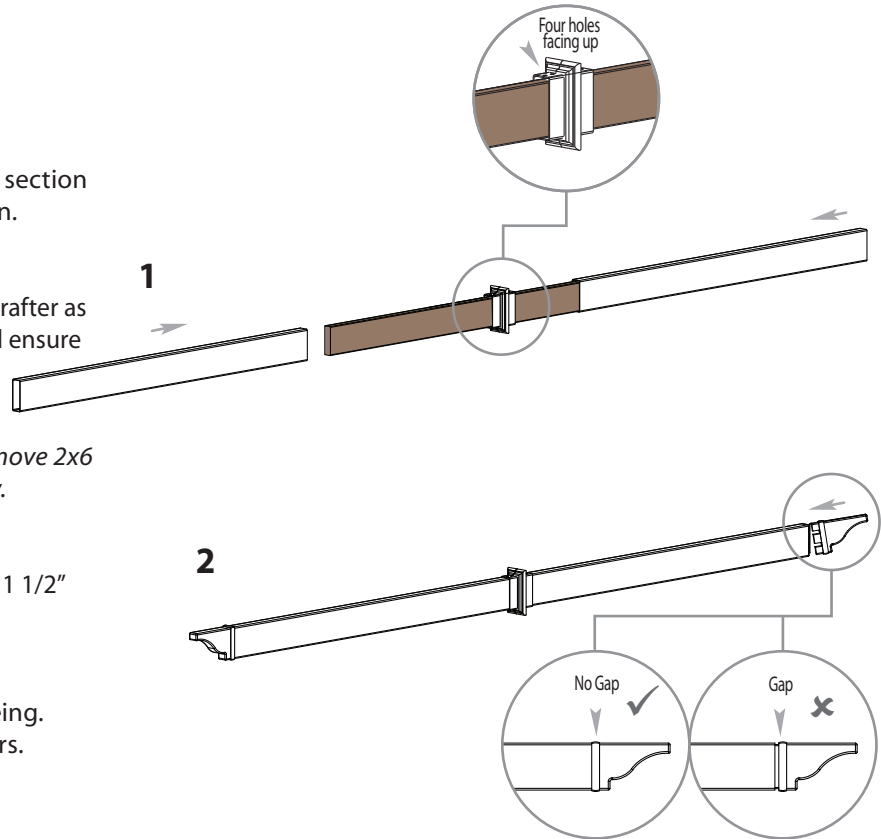

CHADSWORTH COLUMNS

3

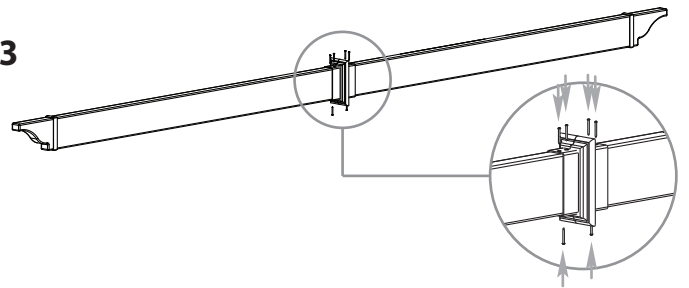

4

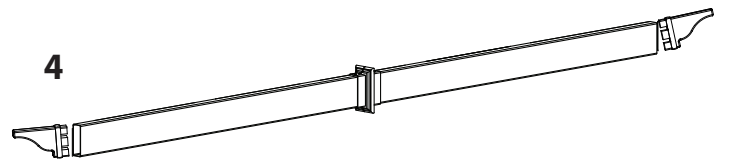

STEP SIX

Vinyl Beams & Rafter Placement

Using a helper and two ladders proceed to complete the following steps:

1

Slide the vinyl beam with rafter clips pre-installed through both holes of the vinyl column (overshooting), and then back through both holes of the opposite column. Repeat for opposite beam.

Please Note:

The top of the vinyl columns may need to be tensioned in opposite directions to each other to allow the beams and rafters to be installed on a slight angle. The vinyl columns naturally allow some measure of flex.

2

Slide the two outer rafters through both holes of the vinyl column and through both holes of the opposite column.

3

Final adjust the beams and rafters ensuring the overhang past the columns is equal to the eye. Using 4" screws lock the beams and rafters into position inside the posts by driving in 8 screws from the outside and 8 screws from the inside of each column. Pre-drill to accommodate for installation of screws into steel channel located in the lower pocket of the rafters and beams.

4

Place the rafters in the front and rear rafter brackets.

5

Complete a final adjustment of all beams and rafters. All spacing and overhangs past columns should be equal to the eye.

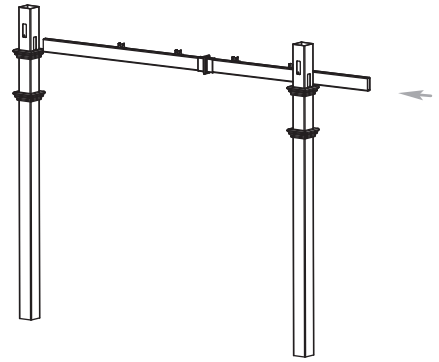

1

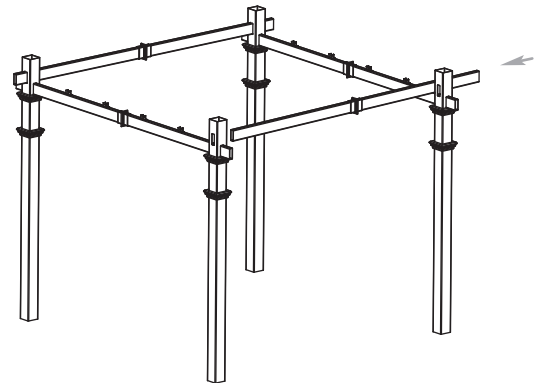

2

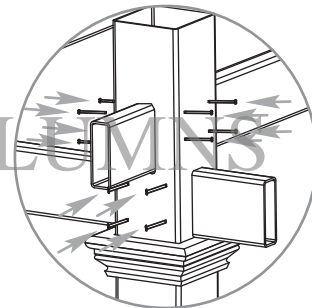

3

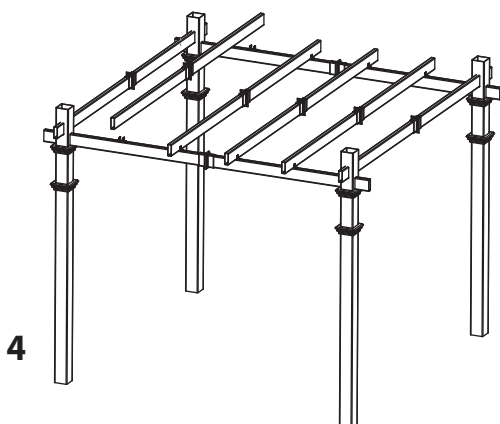
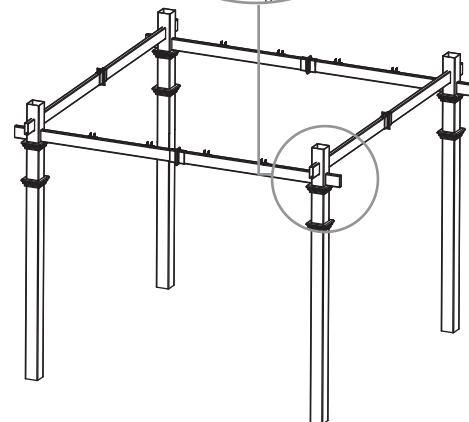

4

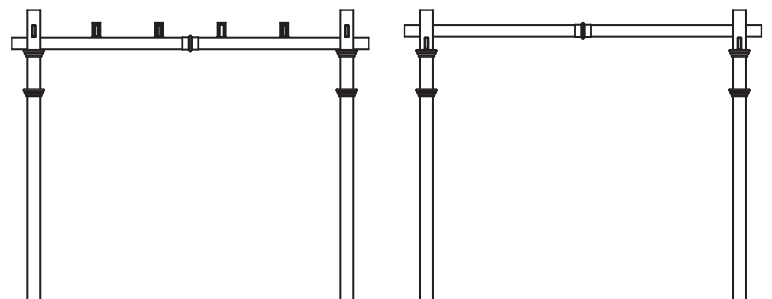

5

STEP SEVEN

Fastening Vinyl Beams, Rafters & Caps

1

Using 5/8" self-auguring stainless steel screws attach the pergola rafters to the rafter brackets.

2

Install decorative pergola end caps using vinyl weld.

3

Install the post caps using vinyl weld.

4

Final position your post trims.

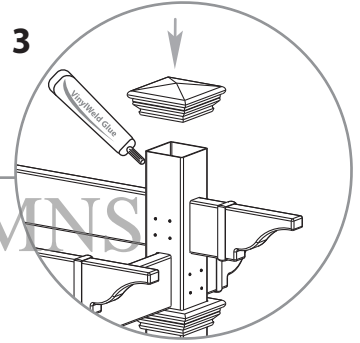
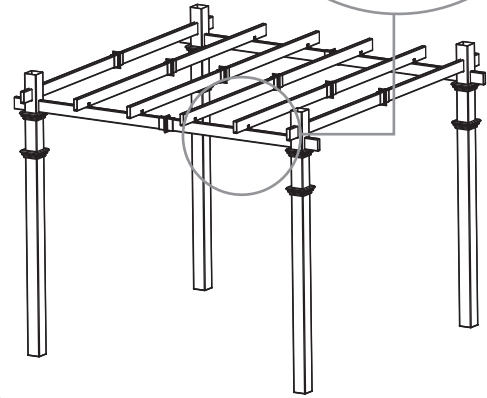
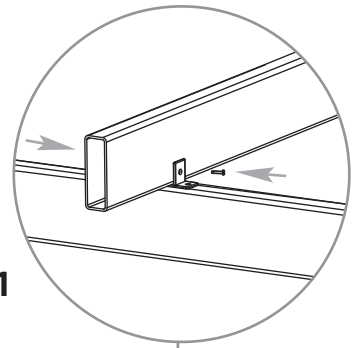
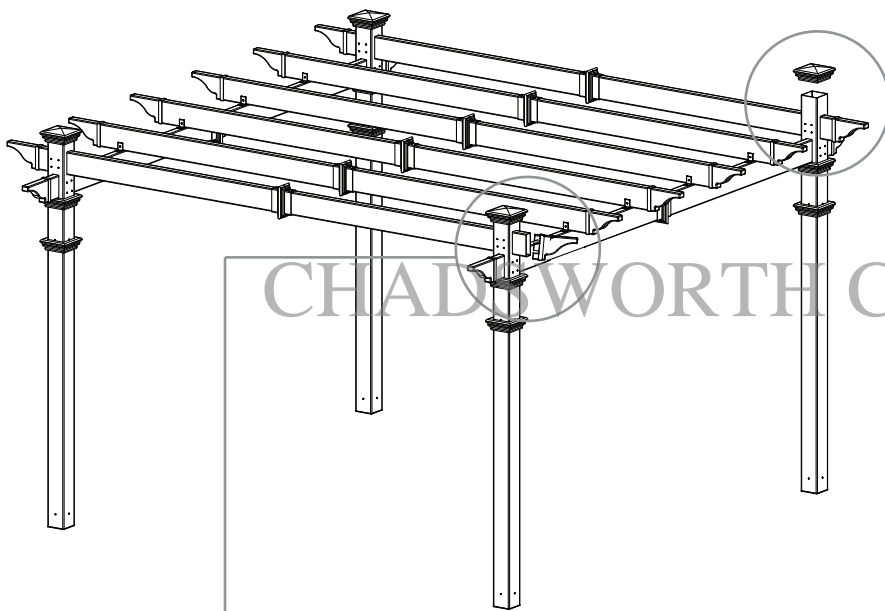

2

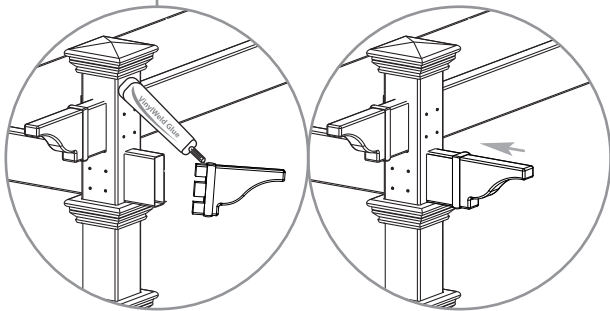

4

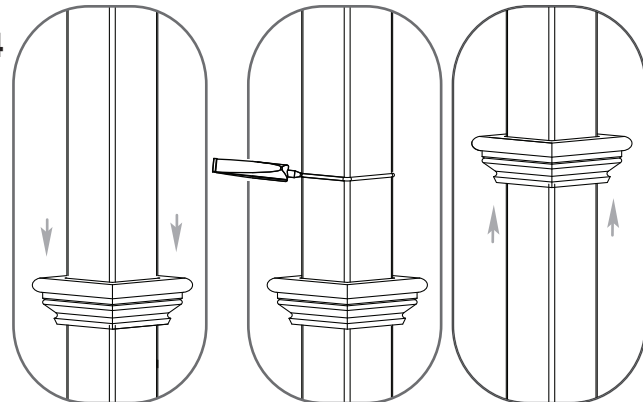

To glue pergola end in place:

1. Apply a generous amount of vinyl glue to the pergola end as shown.
2. Slide the pergola end into the beam/rafter and allow a few minutes for glue to cure.

To position post trim in place:

1. Slide the post trim down.
2. Apply a generous amount of vinyl glue around the post
3. Slide the post trim back up to the desired location and allow a few minutes for glue to cure.

STEP EIGHT

Shade Slat Assembly

1

Assemble shade slats by inserting the two slats into one joiner. Push firmly until extrusion bottoms out inside joiner. **No screws are necessary.**

Shade Slats Installation

The 1 1/2 x 1 1/2 shade slats are designed to be installed with 8 11/16" spacing between each slat.

Shade slats are designed to extend approximately 8 1/4" past the last rafter. Measurement includes the pre-installed pergola ends. Your goal is to ensure that all the shade slats overhang equally to the eye.

2

Install first shade slat adjacent to the top of the vinyl columns.

3

Install the rest of the shade slats at the 8 11/16" spacing.

4

Install one 2 1/2" screw at each intersection of rafter and shade slat.

Suggestions for Additional Shade as Necessary

- White resin lattice in variety of shapes and sizes are available at your local lumberyard. Cut to size and fasten directly to the top of shade slats using stainless steel screws.
- In areas of extreme snow or wind load, do not use tight diamond privacy lattice.

